

**INVESTIGATION OF APPROPRIATE
CONTROL MEASURES
(ABATEMENT TECHNOLOGIES)
TO REDUCE BLACK CARBON
EMISSIONS FROM
INTERNATIONAL SHIPPING**





**Investigation of appropriate control measures
(abatement technologies) to reduce
Black Carbon emissions from
international shipping**

Published in 2015 by the
INTERNATIONAL MARITIME ORGANIZATION
4 Albert Embankment, London SE1 7SR
www.imo.org

Copyright © International Maritime Organization 2015

*All rights reserved.
No part of this publication may be reproduced,
stored in a retrieval system, or transmitted in any form or by any means,
without prior permission in writing from the
International Maritime Organization.*

The views and conclusions drawn in this report are those of the authors of the report.

This publication has been prepared from official documents of IMO, and every effort has been made to eliminate errors and reproduce the original text(s) faithfully.

Contents

Page

- Foreword v
- List of abbreviations vii
- 1 Introduction** 1
 - 1.1 Black Carbon. 1
 - 1.2 Black Carbon from ships 1
 - 1.3 The Impact of Black Carbon from ships on the Arctic. 1
 - 1.4 The International Maritime Organization and Black Carbon from ships. 2
- 2 Measurement and data availability** 3
 - 2.1 Black Carbon measurement and data availability 3
 - 2.2 Particulate Matter as a proxy for Black Carbon. 3
 - 2.3 Fuel efficiency improvements as a proxy for Black Carbon reduction 4
 - 2.4 Primary abatement metrics 4
 - 2.5 Secondary abatement considerations 4
 - 2.6 Technology maturity 4
 - 2.7 Technology uptake time 4
- 3 Black Carbon abatement options** 5
 - 3.1 Fuel efficiency – vessel design (excludes engine, fuel options) 5
 - 3.2 Fuel efficiency – monitoring options 6
 - 3.3 Fuel efficiency – engine options. 6
 - 3.4 Slow steaming. 7
 - 3.5 Fuel treatments 8
 - 3.6 Fuel quality – traditional fuels 9
 - 3.7 Alternative fuels. 10
 - 3.8 Exhaust treatment 11
 - 3.9 Summary of data sources and sampling protocols for BC abatement 13
- 4 Short-list selection of BC abatement options** 17
- 5 Cost and feasibility of BC abatement technologies** 21
 - 5.1 Abatement technology case by case 21
 - 5.2 Slow steaming – with de-rating 21
 - 5.3 Water-in-fuel emulsion (WiFE) 22
 - 5.4 Heavy fuel oil (HFO) – distillate 23
 - 5.5 LNG/DME. 24
 - 5.6 Diesel particulate filters (DPF) 25
 - 5.7 Scrubbers – high sulphur 25

6	Comparison of abatement technologies	27
6.1	Introduction to assessments	27
6.2	Comparisons of technologies	28
6.3	Cost of reducing BC in example vessels	30
6.4	Assessment of feasibility	33
6.5	Feasibility in a regulatory context	35
6.6	Overview of technologies	36
7	References	39
	Appendices	47
Appendix A	Cost overview	49
Appendix B	Calculations according to Corbett	51
Appendix C	Cost and BC reduction overview: ship types 10 MW with Aframax tanker base case	55
Appendix D	Cost and BC reduction overview: similar docking size; varying MW	63
Appendix E	Extract of Erria report	71

Foreword

This study was carried out using funds provided to IMO by Transport Canada for analytical studies and other activities pertaining to the control of air related emissions from ships. The study was tendered under the title 'Investigation of appropriate control measures (abatement technologies) to reduce Black Carbon emissions from international shipping' and was won by a consortium led by LITEHAUZ (Denmark). The participants responsible for the study were Dr Daniel A. Lack, currently at the University of Colorado, Boulder, USA; Mr Jørgen Thuesen and Mr Robert Elliot, ERRIA, Denmark; and Dr Frank Stuer-Lauridsen, Mr Svend B. Overgaard and Ms Ditte Kristensen, LITEHAUZ, Denmark.

List of abbreviations

AHTS	Anchor Handling Tug Supply
AMSA	Arctic Marine Shipping Assessment
BC	Black carbon
CA	Commercially available
CAPEX	Capital expenditure
CO ₂	Carbon dioxide
DE	Demonstration
DME	Dimethyl ether
DOC	Diesel oxidation catalyst
DPF	Diesel particulate filters
ECA	Emission control area
EEDI	Energy efficiency design index
ESP	Electrostatic precipitators
FW	Freshwater scrubbers
HFO	Heavy fuel oil
IM	Immediate
IMO	International Maritime Organization
IN	Intermediate
LNG	Liquefied Natural Gas
LT	Long-term
MARPOL	International Convention for the Prevention of Pollution From Ships
MCR	Maximum Capacity Rating
MDO	Marine distillate oil
MEPC	Marine Environment Protection Committee
MT	Medium Term
NA	Not available
NR	Not reported
NO _x	Mono-nitrogen oxides
OPEX	Operating expense
OS	Other sectors
OSV	Off-shore Supply Vessel
PM	Particulate matter
SCR	Selective catalytic reduction
SEEMP	Ship Energy Efficiency Management Plan
SFOC	Specific fuel oil consumption
SO _x	Mono-sulphur oxides
SSDR	Slow-steaming de-rating
SWS	Seawater scrubbers

UI	Unlikely Implementation
ULSD	Ultra-low sulphur diesel
VOC	Volatile organic compound
WiFE	Water-in-fuel emulsion

1 Introduction

1.1 Black Carbon

Black Carbon (BC) is the product of incomplete combustion of organic fuels. Specifically, it is strongly light absorbing across the visible wavelength spectrum. The largest sources of BC are fossil fuel, biomass and biofuel combustion.^[1] BC has distinct human health impacts^[2, 3] and is a potent climate forcer creating significant atmospheric warming.^[4] Recent national and international reports provide comprehensive details on the definition, sources and impacts of BC,^[5–7] and the following detailed definition for BC has been proposed to the International Maritime Organization (IMO) by the Institute of Marine Engineering, Science and Technology:^[8]

Black Carbon (BC) is strongly light absorbing carbonaceous material emitted as solid particulate matter created through incomplete combustion of carbon-based fuels. BC contains more than 80% carbon by mass, a high fraction of which is sp^2 -bonded carbon, and when emitted forms aggregates of primary spherules between 20 and 50 nm in aerodynamic diameter. BC absorbs solar radiation across all visible wavelengths and freshly emitted BC has a mass absorption efficiency of $5 \text{ m}^2\text{g}^{-1}$ at the mid-visible wavelength of 550 nm. The strength of this light absorption varies with the composition, shape, size distribution, and mixing state of the particle.

1.2 Black Carbon from ships

BC emissions from the international commercial shipping industry are thought to contribute about 1 to 2% of global BC.^[9] Ships emit more particulate matter (PM) and BC per unit of fuel consumed than other fossil fuel combustion sources due to the quality of fuel used.^[10] BC emissions from ships contribute (as a component of PM) to increased human morbidity and mortality.^[11] Several other studies have also been undertaken into the impact of shipping emissions.^[12, 13, 14]

1.3 The Impact of Black Carbon from ships on the Arctic

With the dramatic decline of Arctic sea ice over the past few decades, culminating in a minimum sea ice extent of 4.28 million km^2 in 2007 (compared to ~ 10 million in 1970) [15], comes the possibility of regular transits of the Arctic by commercial shipping traffic. New data from mid September 2012 shows even lower minimum ice coverage of 3.41 million km^2 . The ice loss rate was in the 2012 season 91,700 square kilometres per day, as opposed to 66,000 square kilometres per day in 2007.^[15] Journeys between Asia and Europe and Eastern US and Asia through the Arctic could cut travel distances by 25% and 50% respectively, with coincident time and fuel savings also resulting. The exploration for, and development of resource reserves (e.g. oil, natural gas, forestry), and increased access to fisheries will also drive an increase in localized shipping traffic.^[16–18] Exploitation of opening Arctic shipping routes may be restricted or delayed by several factors. Reductions in multi-year sea ice in some areas of the Northwest Passage (NWP) and Northeast Passage (NEP) will be required to improve Arctic transit viability. Vessel redesign and construction may be needed, appropriate weather conditions in an ice-reduced regime are not assured and new regulations are likely to arise for emergency response, ice charting, ice breaking and national sovereignty issues.^[16–19]

The climate of the Arctic region is known to be warming at almost twice the rate of the rest of the world.^[4, 16] The mechanisms of this warming, and in consequence Arctic sea ice and snow loss, are closely linked to surface air temperatures, ocean circulation and radiative fluxes.^[20] The majority of influence on the radiative forcing in the Arctic is from external (i.e. outside of the Arctic) emissions of greenhouse gases and particulate matter,^[16, 21] with possibly half of Arctic temperature rise linked to BC.^[21] Most Arctic BC pollution is sourced from anthropogenic and biomass burning activity within Eurasia,^[22] and outside of strong biomass burning

years BC levels may be stabilizing or decreasing in the Arctic.^[21, 23–25] Recent work shows that also ship BC emissions from outside of the Arctic can contribute to Arctic warming.^[32]

Increases in Arctic shipping will introduce direct near-surface emissions of pollution, including BC. These direct emissions are significant contributors as Arctic warming is most sensitive to emissions within the region compared to the current emissions where most must survive long-range transport from its source before directly impacting the region.^[21, 26] The warming efficacy of BC in the Arctic is at least double that of CO₂, as it absorbs incoming and snow-reflected radiation^[22] and accelerates snow and ice melting when deposited to those surfaces.^[27] It is therefore likely that any climate benefits of BC reductions within traditional shipping routes will be met with increases in the warming effect of BC emissions across the new Arctic routes. Current and future inventories of Arctic BC from shipping activities have been developed predicting significant increases of BC emissions in future years.^[28, 29] The use of these inventories to model the climate impacts of ship-emitted BC show that regional scale effects are difficult to distinguish from the impacts of other BC sources. However, shipping BC potentially contributes up to 50% of BC in some regions of the Arctic^[31] and localized increases in snow and ice melt do occur near the projected shipping lanes.^{[30, 31] [32]}

1.4 The International Maritime Organization and Black Carbon from ships

In recent years the IMO has introduced international regulation to reduce emissions of nitrogen oxides^[33] and the sulphur content of fuel,^[34] which are linked to ground level ozone and particulate matter, and both of which have an impact on human health. In addition, the IMO has also commissioned studies in the impacts of greenhouse gases from ships^[35] and subsequently introduced carbon dioxide reduction measures in the form of a ship energy efficiency design index (EEDI) requiring continual improvements in ship efficiency.^[36] Efforts to investigate the definition, measurement and impact of BC emissions from shipping have been initiated.^[37]

Discussion on reduction of PM from ships at the IMO, with specific or implied reference to BC, arose from the establishment of a correspondence group during the 10th session of the Bulk Liquids and Gases subcommittee.^[38] This correspondence group was established, “with a view to controlling emissions of particulate matter (PM), study current emission levels of PM from marine engines, including their size distribution, quantity, and recommend actions to be taken for the reduction of PM from ships”.^[38] The group reported to BLG 11 (2007)^[39] on multiple options for reductions in all PM, some of which specifically suggested PM (rather than just fuel sulphur or particulate sulphate) limits. During BLG 12 (2008),^[40] Norway submitted a paper recommending a standard for PM measurement (ISO 9096) that was compatible with the high sulphur fuel used in many ships,^[41] thereby establishing an important benchmark for the following discussions of reliable measurement protocols. At MEPC 59 (2009)^[42] the United States and Canada submitted a proposal to the IMO to establish an emission control area (ECA), for control of SO_x, PM and NO_x emissions.^[42] This North American ECA was approved at MEPC 60 in 2010.^[43] Also during MEPC 60, Norway, Sweden and United States provided an outline of the effects of BC on the Arctic and suggested possible actions for mitigation of BC from ships.^[44] During MEPC 61 (2010)^[43] the IMO agreed in relation to BC from ships “to invite interested Member Governments and international organizations to submit concrete proposals with specific measures to BLG 15”. Information papers were submitted to BLG 15 (2011)^[45] relating to an international report on the science of BC and climate^[46] and the impacts of ship BC on the Arctic.^[32] Further discussions on BC at BLG 15 and MEPC 62 (2011)^[37] led to the following tasks to be identified for the BLG subcommittee:

1. develop a definition for Black Carbon emissions from international shipping;
2. consider measurement methods for Black Carbon and identify the most appropriate method for measuring Black Carbon emissions from international shipping;
3. investigate appropriate control measures to reduce the impact of Black Carbon emissions from international shipping; and
4. submit a final report to BLG 17.

BLG 16 (2012) saw six informational submissions on ship BC issues ^[8, 47–51] related to these four points. The submissions include suggestions for definitions, appropriate measurement techniques (i.e. techniques, not measurement protocols) as well as two presentations, and in addition to establish a working group on *Consideration of the Impact on the Arctic of Emissions of Black Carbon from International Shipping* to address in more details the four points above. This document is expected to contribute to point 3 of the BLG correspondence group. The relevant IMO information papers have been assessed and used, where appropriate, in this report.

2

Measurement and data availability

2.1 Black Carbon measurement and data availability

The availability of BC mass emission data from ship engines and relative measurements of BC mass before and after treatment of fuels or exhaust is limited. Particularly relative to other BC sources such as on-road diesel engines. It is recognized that there are strengths and weaknesses to various measurement techniques,^[2] however, Lack and Corbett^[10] reviewed the measurement of BC and related species such as elemental carbon (EC) from ship engines. The findings show that, within an uncertainty of approximately $\pm 20\%$, most analytical methods for measuring the mass of the strongly light absorbing material defined as BC, are the same. Since there is a strong lack of data availability for shipping BC abatement technologies, this review paper will consider all the available BC and PM data with emphasis on peer-reviewed data, with appropriate caution placed on indirect measures of BC (discussed below).

The majority of research into the emissions of BC from diesel engines is sourced from the on-road diesel fleet (trucks and buses) where significant fuel-quality, fuel treatment and exhaust treatment regulations have been mandated.^[52–54] Some of these regulations have only just emerged for the commercial shipping industry^[34] and measurement campaigns for ship emissions have not been prioritized due to former lack of regulation and difficulty in accessing or instrumenting large commercial ships and engines.

Where available, measurements of BC from ship engines are used in the assessment of abatement technologies. However, to make the full assessment of technologies, measurements of species similar to BC (see Lack and Corbett^[10]) and alternative proxies for BC and BC emission reductions were in some cases considered.

2.2 Particulate Matter as a proxy for Black Carbon

BC is a component of PM mass, the contribution of which is dependent on the combustion source. For example, BC from biomass burning comprises 2% to 5% of total PM mass^[55] where BC from engines burning ultra-low sulphur diesel can range from 65% to 75% of PM mass.^[56, 57] BC is also formed within a diameter range of 20 to 250 nm,^[e.g. 58–60] unlike PM which can range up to many 1000s of nm^[61] and commonly measured and reported as PM10 (<10 μm diameter) or PM2.5 (<2.5 μm diameter).

Where BC mass measurements were not available, PM mass measurements were used as a proxy if one of the following criteria were met:¹

- Where BC and PM removal were not expected to differ based on the abatement technology. For example, BC is known to be hydrophobic upon emission from many sources. Scrubbing technology that relies on particle wetting may have different removal rates. In contrast a filter will remove particles of the same size regardless of composition.
- Where PM removal rates were provided as a function of PM size, extrapolation to a BC removal rate is possible.

For one study particle number was the only particle measurement available. We view this as a semi-quantitative proxy for BC.

¹ Information regarding whether bulk PM, or size selected PM was used as a proxy for BC in this review is summarized for each abatement technology in table 9.

2.3 Fuel efficiency improvements as a proxy for Black Carbon reduction

BC emission is directly proportional to fuel consumption (at full engine load).^[10] At reduced engine load, or inefficient operation of the engine, this direct proportionality is not likely to hold.^[10] In the assessment of fuel efficiency measures for BC reductions, it is assumed that when a measure reports a fractional change in fuel consumption that BC mass emissions will also reduce by this amount.²

2.4 Primary abatement metrics

All PM or BC reductions are given as a percentage reduction from the units presented in the literature. This could be PM or BC mass per unit fuel consumed, per distance travelled or per unit of work. The use of relative PM, or BC reductions eliminates the need to convert data into a single unit. In each table up to three numbers are given for BC abatement potential for each technology: LOW/MID/HIGH; which represents the lower, middle and upper bound of abatement potential identified from literature. A negative number indicates an increase in BC emissions. Where a middle abatement potential is not discernible from literature an average between the lower and upper bounds is used. This method of presenting abatement potential is also used for CO₂ reduction assessment.

2.5 Secondary abatement considerations

While BC is the primary abatement focus, the IMO has also spent significant effort in the abatement of CO₂, NO_x and SO_x. In this review the BC abatement option is also assessed with regards to the technology's reduction of CO₂ and the qualitative abatement potential for NO_x and SO_x. These assessments are considered as co-benefits to the BC abatement technology.

2.6 Technology maturity

The overall purpose of this review is to provide input to IMO's assessment of available instruments for regulating this area. In order to fully address the availability of the abatement technologies the Long List assessment of abatement options given in this review therefore includes an estimate of the maturity of the technology. These include:

CM: *Commercially Available* – Multiple units operational in the shipping sector.

CF: *Commercially Available* – Few units operational in the shipping sector.

DE: *Demonstration* – Feasibility demonstrated in the shipping sector, but it is not commercially available yet.

OS: *Other Sectors* – Technology is commercially available in other sectors and potentially applicable in shipping.

NA: *Not Available* – Technology may not be available in the long term.

2.7 Technology uptake time

The long list assessment of abatement options includes an estimate of implementation time based on the maturity of the technology, requirements for retro-fit, ship newbuilds, research or design.

IM: *Immediate* – <12 months. Commercially available.

IN: *Intermediate* – 1 to 5 years. Commercially available, but major retro-fit or newbuild required.

MT: *Medium Term* – 5 to 10 years. Not commercially available. Design/experimental stage and will require further development, research and commercialization.

LT: *Long-Term* – >10 years. Major design, safety and commercialization effort necessary.

UI: *Unlikely Implementation* – Technology unlikely to be implemented.

² Details of when this BC proxy is used when assessing the abatement technologies are given in table 9.

3

Black Carbon abatement options

BC abatement technologies are assessed within the following categories:

- Fuel efficiency – vessel design
- Fuel efficiency – monitoring options
- Fuel efficiency – engine options
- Slow steaming
- Fuel treatments
- Fuel quality (traditional fuels)
- Alternative fuels
- Exhaust treatment

The fuel efficiency measures presented are mostly summaries of a number of the high-return options from the guide to ship eco-efficiency technologies and measures.^[62] A full lifecycle assessment of fuel production, waste disposal and new ship builds with inclusion of externalized cost should be considered for each new abatement technology, but it is beyond the scope of the current study. Currently, the data availability and data quality of the majority of the technology options regarding life cycle assessment do not render such an exercise feasible.

3.1 Fuel efficiency – vessel design (excludes engine, fuel options)

Improved fuel efficiency through vessel redesign will save fuel costs and reduce emissions. Many fuel-efficient vessel design options are currently available. An energy efficiency design index (EEDI) has been adopted by the IMO^[36] and requires step-wise improvements to the energy efficiency of new build ships, starting at 10% reduction in CO₂ per tonne-mile from 2015, increasing to 20% and 30% from 2020 and 2025, respectively. The options for improved efficiency are left to the designers, builders and owners of the new ships,^[63] and presumably will allow the most cost-effective options to be developed and integrated into new ship builds. The EEDI will reduce fuel consumption (and thus fuel costs) and these reductions in CO₂ emissions will simultaneously reduce the emissions of co-emitted species such as BC. Where fuel efficiency measures are implemented that move the engine away from efficient combustion, e.g. reduced engine load during slow steaming,^[10] this linear co-reduction of BC will likely not occur. Future vessels designed for slow steaming will likely incorporate lower power engines so they can operate near the maximum engine load, or will use engines that can be de-rated or re-tuned for the lower load. For all measures where maximum engine efficiency is maintained it is assumed that those measures implemented by industry will provide co-benefit reductions in BC emissions. The options, and estimated efficiency improvements, for such efficiency measures are presented in table 1.

Table 1 – Fuel efficiency options (excludes engine and fuel options)^a (nr: not reported)

Abatement measure	↓CO ₂ %			↓BC %			Technology maturity	Uptake time	Remarks	Ref.
	low	mid	high	low	mid	high				
EEDI	10	20	30	10	20	30	CA1 CA2 D	2015/2020/2030	Required due to regulation. Newbuilds, >400 tonnes	[36]
Ballast water and trim	1	4	5	1	4	5	CM	IM		[62]
Propeller optimization ^b	3	nr	20	3	nr	20	CM	IM		[62]
Construction weight	nr	5	nr	nr	5	nr	CF	IN	Newbuild required	[62]
Air lubrication	3.5	10	15	3.5	10	15	CF	IM	Retro-fit or newbuild required	[62]
Aerodynamics	3	nr	4	3	nr	4	DE	IN	Retro-fit or newbuild required	[62]
Hull coatings	2	5	9	2	5	9	CM	IM	Material and dry dock costs	[62]
Hull cleaning	3	5	10	3	5	10	CM	IM	Labour and dry dock costs	[62]
Wind – Fletner rotors	3.6	nr	12.4	3.6	nr	12.4	DE	MT	Design, commercialization	[62]
Wind – sail/kites	2	nr	26	2	nr	26	CF	IM	Capital cost	
Solar	5	nr	17	5	nr	17	DE	IN	Retro-fit or newbuild required	[62]

^a All efficiency measures in this section are assumed to produce reductions in NO_x and SO_x

^b Combination of multiple technologies from^[62]

3.2 Fuel efficiency – monitoring options

Fuel efficiency improvements due to sophisticated monitoring of ship systems and weather may also contribute to the overall efforts to reduce fuel consumption from ships. There are currently monitoring options available for efficient routing of ships around weather systems and for efficient autopilot operations. Any fuel efficiency gains from these systems will also reduce BC emissions.

Table 2 – Fuel efficiency options (monitoring options)^a (nr: not reported)

Abatement measure	↓CO ₂ %			↓BC %			Technology maturity	Uptake time	Remarks	Ref.
	low	mid	high	low	mid	high				
Weather routing	2	nr	10	2	nr	10	CM	IM		[62]
Auto-pilot upgrades	0.5	nr	4	0.5	nr	4	CM	IM		[62]

^a All efficiency measures in this section are assumed to produce reductions in NO_x and SO_x

3.3 Fuel efficiency – engine options

3.3.1 Slide valves

Slide valves are commercially available technology used as a retro-fit options for traditional marine diesel engine valves that optimize fuel injection spray patterns.^[64] Available data would suggest that there are neutral or improved (1% at best) fuel efficiency responses from the use of slide valves.^[65–67] This technology has been successfully applied to reduce NO_x emissions while also showing reductions in emitted PM and VOC. MAN Diesel and Turbo^[68] suggest that slide valves are an essential retrofit for slow steaming where de-rating is not possible (see section 3.3.2). There is one report of a 2% fuel consumption increase with the use of slide valves.^[69] Corbett *et al.*^[65] assessed the potential for BC reductions for slide valves, concluding that reported PM reductions were equivalent to BC reductions (at 25%). This technology will have the largest impact on older engines^[70] and it is becoming standard on new engines.^[e.g. 71] Since slide valves reduce NO_x emissions the uptake of this technology is partially motivated by IMO NO_x regulations.

3.3.2 Tuning of fuel injection, timing and pressure, and de-rating

Real time electronic monitoring and tuning of diesel engine parameters, such as fuel injection pressure and timing and fuel atomization quality, allow for optimum combustion characteristics as engine loads change.^[71, 72] Sub-optimal combustion leads to increased fuel consumption between 1% and 3%,^[62, 72] and cause BC formation. The optimization of combustion conditions with engine load (or power demand) can also be achieved through the use of engines with cylinders that can be brought on and off line (i.e. traditional de-rating).^[72] This technology is available on new marine diesel engines and would require new engine installation.

Engines that use real time tuning of fuel injection parameters and common rail fuel injection^[73] will have substantially reduced BC emissions at loads below that originally rated for the engine. The extent of reduction of BC emissions depends on the load of the engine as discussed in the slow-steaming section (3.4).

Table 3 – Fuel efficiency options (engine options)^a

Abatement measure	↓CO ₂ %	↓BC %	Technology maturity	Uptake time	Remarks	Ref.
	low mid high	low mid high				
Slide valves	1 0 -1	10 25 50	CM	IM	Motivated by IMO NO _x regulations. Hardware cost	^[65]
Real time tuning, de-rating	1 2.5 4	1 2.5 4 ^b	CM	IN	New engine needed	^[62, 72]

^a All efficiency measures in this section are assumed to produce reductions in NO_x and SO_x

^b BC reduction from reduced fuel consumption only. BC reductions from improved combustion conditions discussed in slow steaming section (3.4)

3.4 Slow steaming

Slow steaming is a reduction from full ship speed to a lower speed. This option is attractive for reductions in emissions from ships, as fuel consumption increases as a cubic function of vessel speed.^[74] This means a 10% decrease in speed will lead to a ~27% decrease in fuel consumption.^[75] An increase in the transit time of a ship will lead to a reduced capacity to move goods and maintain delivery schedules. If this lost capacity is replaced in the form of additional ships the added cost reduces the benefits of slow steaming. A 10% reduction in speed therefore results in a net 20% reduction in fuel consumption overall.^[75, 76] Since 2008 (global financial crisis) many ship companies have reduced ship speeds to reduce fuel consumption (thus cutting costs). One report suggest that since 2008 the average speed of the global shipping fleet has reduced speed by 15%^[77] which would suggest a 30% to 40% reduction in fuel consumption. MAN Diesel and Turbo^[68] conducted a survey that revealed that 75% of the global bulk and container shipping fleet was conducting some form of slow steaming during 2011, with many operating in this manner since 2007. The majority of survey respondents operated at between 30% and 50% engine load. AP Moller Maersk have reported a 22% reduction in fuel costs resulting from reducing engine load from 100% to 40% for 73% of their fleet.^[78] With reduced fuel consumption comes a corresponding reduction in CO₂ and some other emissions. Based on this literature review, further discussion on slow steaming is done assuming an engine load reduction from 100% to 40% (in speed, from 25 knots to 18 knots).

3.4.1 Slow steaming without re-tuning/de-rating

If a ship reduces speed without any adjustment to the engine combustion process, BC emissions can increase due to inefficiencies in combustion.^[10, 79, 80] MAN Diesel and Turbo note that it is common for soot build-up to occur within the engine when running at loads less than 100%.^[68] Lack and Corbett^[10] reviewed 40 different measurements of BC emissions under varying engine loads and showed that absolute BC emissions (mass per distance travelled) can increase by an average of 30% if the engine load is reduced to 40% when the engine is not re-tuned to the new load (see figure 1). Load reductions from 100% to 20% and 10% can increase BC emissions by 60% and 90% respectively. In another example entailing AP Moller Maersk vessels, it was found that engine load reductions from 60% to 35% could have led to a 7% increase in absolute emissions of BC if the engines were not re-tuned.^[10] Based on the review of available data, BC emissions appear to remain constant over the load range of 80% to 100%^[10] and BC emissions are therefore likely to increase when speed reductions are obtained from engine load <80%.

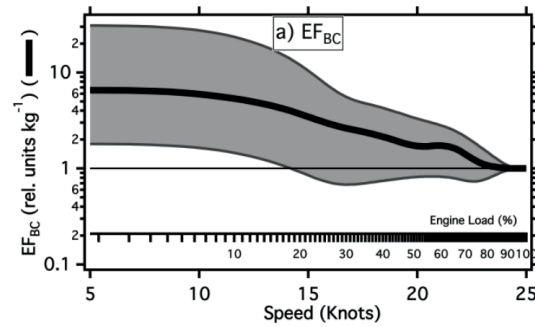

Figure 1: BC mass changes per distance travelled as a function of vessel speed. Reproduced from Lack and Corbett^[10]

3.4.2 Slow steaming with de-rating/re-tuning/slide valves

Fuel efficiency gains and emission reduction potential of real-time tuning, slide valves and de-rating of engines were discussed in section 3.3. These processes have the potential to reduce fuel consumption by 1% to 4%. The use of this technology can counteract the significant increase in BC emissions caused by operation of engines at lower loads (section 3.4.1). Theoretically, re-tuning/de-rating of engines to provide ideal combustion at all loads would reduce BC emissions in line with the reductions in fuel consumption. For example, the 7% reduction in CO₂ emissions per container moved (2008 to 2010) presented by AP Moller Maersk^[76] would result in a 7% reduction in BC emissions per container moved. Likewise, the load reductions shown in the example by Lack and Corbett^[10] would provide 20% reductions in BC emissions. Whether ideal re-tuning and de-rating can be achieved is a question with little data to provide guidance. Slide valves are also suggested as an essential technology for significant reductions in BC emissions during slow steaming when re-tuning or de-rating is unavailable.^[68]

Table 4 – Summary of Slow Steaming as an abatement option (100% load – >40% load). (nr: not reported)

Abatement measure	↓CO ₂ % low mid high	↓BC % low mid high	↓NO _x	↓SO _x	Technology maturity	Uptake time	Remarks	Ref.
Slow steaming: no de-rating	7 nr 25	0 nr –30 ^a	N ^b	Y	CM	IM	Fuel savings, increased travel time	[10, 75, 76, 78]
Slow steaming: with de-rating/re-tuning/slide valves	8 nr 29	0 nr 30 ^a	Y	Y	CM	IN	New engine needed	[10, 62, 72, 76, 78]

^a BC reductions based on the load changes presented in the references provided

^b NO_x emissions remain the same until low engine loads (<20%) where they increase

3.5 Fuel treatments

3.5.1 Colloidal catalysts

Heavy metals such as cerium and vanadium are known to catalyze the combustion of BC.^[81] When introduced into liquid fuels as a colloid, the fuel atomization process is improved leading to improved fuel consumption and heavy metal particles at the point of BC formation, thus reducing the extent of BC formation.^[62, 82] On land transportation vehicles these colloidal catalysts are often combined with particulate filters to reduce overall PM emissions.^[83] It has been suggested that HFO, having relatively high concentrations of vanadium, will produce less BC emissions than cleaner fuels, due to this catalytic effect.^[84] Quantitative data on the effectiveness of colloidal heavy metal catalysts independent of other technologies is scarce, particularly for HFO.

3.5.2 Water-in-Fuel Emulsion (WiFE)

Water-in-fuel emulsions lead to improvements in combustion by improving the atomization of the fuel and have shown emission reductions within the marine and on-road sectors. In the review of Corbett *et al.*^[65]

WiFEs were shown to reduce PM emissions by 42% to 63%, with one study reporting that BC emissions were reduced preferentially over PM (70% to 85% BC reduction compared to 44% to 57% PM reduction).^[65] Corbett *et al.* concluded that reductions in BC emissions were at least equivalent to PM reductions, assuming 50% BC reductions. This review also suggested that there was an increase in fuel consumption of 1.5%. Recent reports from NoNO_x LTD^[85] on a variety of combustion engines using diesel suggest that WiFE leads to reductions in fuel consumption of 7% to 15% when 10% to 17% water is added to the fuel (by volume). PM reductions of 60% to 90% were also suggested.^[86] Alternative WiFE systems show that emulsions of water (20%) and HFO can reduce PM emissions by 83%, BC emissions (a crude estimate) by 86%, and CO₂ reductions by 17%.^[87] This CO₂ reductions is consistent with the reductions in fuel consumption of 12% to 18% seen for a WiFE trial with a lighter diesel fuel.^[87] However, only preliminary communications of proprietary studies are currently available with little information on other engine conditions such as the existence of injectors, electronic timing or slide valves.³

Table 5 – Summary Fuel Treatments as an abatement option (nr: not reported)

Abatement measure	↓CO ₂ % low mid high	↓BC % low mid high	↓NO _x	↓SO _x	Technology maturity	Uptake time	Remarks	Ref.
Colloidal catalyst	2 nr 10	nr	Y	Y	OS	IM		[62, 83]
Water-in-fuel emulsion	-1.5 nr 18	50 nr 90	Y	Y	CF	IM		[62, 65, 85, 87]

3.6 Fuel quality – traditional fuels

3.6.1 HFO – distillate

HFO is a fuel used almost exclusively in the marine shipping sector, which contains significantly higher concentrations of sulphur, aromatic hydrocarbon and inorganic ash. All of which are known to reduce fuel combustion efficiency^[88] and produce, amongst other emissions, BC. As discussed in section 3.5.1 there is some suggestion that the high levels of vanadium in HFO can catalyze the combustion of BC as it forms, thus reducing overall BC emissions. However, as mentioned in section 3.5.1 there is no data enabling an assessment of this potential for HFO.

Lack and Corbett^[10] reviewed 19 separate comparisons between HFO and higher quality fuels and concluded that this shift would result in BC reductions between 30% and 80%. This assessment is consistent with a well-established link between fuel quality and BC emissions for on-road diesel engines. The large range of reported BC reduction introduces added difficulty in assessing this abatement option. In addition, some of the trials reviewed by Lack and Corbett^[10] showed increases in BC emissions when moving to cleaner fuels, which has been suggested as evidence for the catalytic effect of vanadium.^[84] However, inconsistencies in measurement results cast uncertainty on this conclusion. Recent data on fuel switching trials on a single vessel show variable results with increased BC emissions (30% to 50%) at low loads for a switch to cleaner fuel, and inconclusive data or decreased BC emissions (35% to 45%) at high loads for the switch to cleaner fuel (results were reported for both auxiliary and main engines).^[80] The conclusions of the review of Lack and Corbett^[10] and data from other-sector literature do, however, provide a balance of evidence that a switch from high sulphur residual fuels to low sulphur distillates, at high loads in particular, will lead to BC reductions. Certainly more research is required using reliable measurement tools to increase the statistics on such a conclusion; however, this report utilizes the current evidence to provide its recommendations.

A switch to cleaner distillate fuels also comes with an increase in energy content of 6% to 8% [80, 89], which will reduce required fuel consumption by the same amount.

³ These studies were obtained directly from the individuals/companies involved and it is our impression that they would be made available to anyone requesting them.

Table 6 – Fuel Switch as an abatement option (nr: not reported)

Abatement measure	↓CO ₂ % low mid high	↓BC % low mid high	↓NO _x	↓SO _x	Technology maturity	Uptake time	Remarks	Ref.
HFO – distillate – energy content	6 nr 8	6 nr 8	N ^a	Y	CM	IM	Fuel cost/availability	[80, 89]
HFO – distillate	0	0 45 80	N ^a	Y	CM	IM	Fuel cost/availability	[10]

^a Studies show slight positive and negative changes of NO_x emissions when cleaner fuel is used^[e.g. 90, 91]

3.7 Alternative fuels

3.7.1 Biodiesel

An extensive review across many transportation sectors of the emissions of biodiesel compared to conventional low sulphur diesel, shows overwhelming evidence for a 50% to 90% reduction in PM emissions. This is due to the lower concentrations of aromatic hydrocarbons, higher cetane numbers (combustion quality) and higher oxygen content in biodiesel.^[92] Mixtures of biodiesel and conventional diesel show progressively decreasing PM emissions as biodiesel content increases.^[92, 93] For example, 20% biodiesel mixtures reduced PM emissions by ~20% to 30%, while 100% biodiesel reduced PM emissions by 50% to 70%. That review focused on the emission reductions using low sulphur diesel as a baseline. As emissions from the combustion of low sulphur diesel predominantly comprises BC and organic matter, the quoted PM reductions are highly probably proxies for BC. Biodiesel contains 8% to 11% less energy than conventional diesel^[90, 92–94] and fuel consumption will therefore increase by this amount. A main driver for biofuels is the reduction in life cycle carbon (CO₂) and it has been suggested that the increased fuel consumption (and CO₂ emissions) from biodiesel are significantly offset by the closed carbon cycle of biodiesel feedstock.

Within the shipping industry a number of biofuel experiments have taken place.^[90, 94, 95] Jayaram *et al.*^[94] showed a 38% reduction in BC using 50% biodiesel/ultra low sulphur diesel mixture, while Petzold *et al.*^[90] showed BC reductions in the range of 60% to 75% for four different biodiesels compared to HFO.

The biodiesels used in all of the studies referenced were sourced from vegetable oil (soya, palm, sun-flower) or animal fats. Biofuels such as methanol, ethanol or dimethyl ether are not considered in this section, although do form part of the discussion in section 3.7.3.

3.7.2 LNG

Extensive reviews of the effect of LNG on PM emissions within light-duty (passenger cars) and heavy-duty diesel engines (buses, trucks) suggest that PM emissions are cut by 88% to 99%.^[96–98] Because the majority of PM emissions from ultra-low sulphur diesel (ULSD) fuel are BC, these PM reductions are likely an effective proxy for BC (see section 2.2). US EPA data suggest that BC emissions are eliminated when using LNG.^[57] No data has been identified on PM or BC emissions from LNG engines used in ships. In terms of the reduction of the global warming (GW) potential, possible fugitive emissions of methane during LNG production may counteract an otherwise positive BC effect from LNG.

3.7.3 Methanol – dimethyl ether (DME) (ethanol – diethyl ether)

DME is the product of the dehydration of methanol, which has a higher cetane number than methanol itself. It can be produced from many sources, i.e. coal, biomass and CO₂. The use of DME directly as a fuel in diesel engines, or the onboard dehydration of methanol to form DME, is the subject of significant research in the assessment of the ‘well to wheels’ potential as an alternative to HFO. The SPIRETH programme [99] is investigating the onboard catalyzed dehydration of methanol or ethanol. Limited data on this fuel source suggests that a 97% drop in particle number results from the use of dehydrated ethanol compared to a diesel engine (presumably running ultra-low sulphur diesel).^[100] Particle number reductions by themselves cannot be confidently applied to BC reductions. The SPIRETH report and a report from Wartsilla^[101] suggests that the use of DME produces “no particulate emissions” or “low or no soot”. On other parameters there appeared to be a 9% reduction in fuel efficiency and a 35% reduction in NO_x emissions, although these were based on one series of measurements.^[100] Methanol storage is reported to have similar storage requirements as LNG^[102] while DME can be integrated into LNG fuel and engine systems.^[103] Production of DME from renewable sources or as by-product from other productions is also showing promise with net CO₂ reductions of 95% when produced from biomass.^[104]

3.7.4 Nuclear

The use of nuclear ships has occurred in military applications, ice breakers and coast guard operations in the Arctic. Nuclear vessels will only have an impact on global emissions when reactor design, ship design, fuel security and waste disposal issues are considered in addition to the substantial delay in fleet replacement. BC emissions from this fuel source could be virtually eliminated. This type of alternative fuel is not considered in any further detail.

Table 7 – Summary of alternative fuels as an abatement option (nr: not reported)

Abatement measure	↓CO ₂ % low mid high	↓BC % low mid high	↓NO _x	↓SO _x	Technology maturity	Uptake time	Remarks	Ref.
Biodiesel – 100%	–5 nr –11	50 nr 75	N	Y	DE	IM	Fuel availability	[90, 92, 94, 105]
Biodiesel – 20%	–1 nr –3	10 nr 30	N	Y	DE	IM	Fuel availability	[92–94]
LNG	15 nr 30	88 nr 99	Y	Y	CF	IN	Engine/ fuel storage retrofit. Port supply of LNG. Fugitive emissions.	[62, 96–98]
Methanol/DME	nr –9 nr	nr 97 100	Y	Y	DE	MT	Fuel storage retrofit and onboard catalysis units required	[99, 100]
Nuclear	nr nr 95	nr nr 95	Y	Y	NA	LT → UN	Design, security and waste issues. CO ₂ and BC emissions from fuel production/disposal	

3.8 Exhaust treatment

3.8.1 Electrostatic precipitators (ESP)

PM is often naturally charged due to rapid airflow around the particle creating static electricity. Electrostatic precipitators (ESP) take advantage of this charge by flowing the exhaust between charged plates, leading to particle precipitation from the exhaust flow. This technology is commonly used in large stationary sources such as mines and factories. The method is an attractive option due to high collection efficiencies and low added energy use, as there only is a minimal pressure drop in the exhaust system. Collection efficiencies for PM sized 40 to 700 nm can range from 60% to 100% by mass.^[106–110] Trials on small engines, where the volume of exhaust is minimal compared to large ship engines, show PM reductions of 80% to 90% between 40 and 700 nm.^[110] Trials on a 4-stroke engine running marine distillate oil (MDO) show PM reductions of 75% to 85% and BC reductions of 50% to 80% across all engine loads.^[106] Some trials report 100% PM removal at larger sizes (~500 nm) and 95% efficiency at smaller sizes (70 nm – the diameters close to atmospheric BC).^[108] One trial performed on a 140 kW engine running on HFO show PM and BC reductions of 60% to 80% across the 40 to 700 nm size range.^[109] ESPs so far have had very limited application to large diesel engines.

3.8.2 Diesel particulate filter (DPF)

Diesel particulate filtration (DPF) is a technology that has been used extensively for reductions in PM emissions within the on-road vehicle sector. DPFs use ceramic or metal filters to trap the PM prior to exhaust emission and periodic cleaning is required. The PM is concentrated in the filter and then combusted via active or passive processes. A DPF results in an added fuel consumption of about 4%^[65, 111] due to exhaust flow

pressure drops.^[70] The combination of ULSD and DPFs are the basis for “clean diesel” and most DPFs are only effective when combined with clean fuels (e.g. <500 ppm sulphur). At high sulphur levels the filters become ineffective or may actually produce PM.^[65]

PM reductions from diesel cars, trucks and buses fitted with DPFs range from 70% to 98%^[65, 97, 112–115] and the option can be used on diesel containing biodiesel and water emulsions up to 5% and 10% respectively.^[112] The use of DPFs on ship engines has been limited; however, one manufacturer claims 99.9% PM reductions for engines up to 600 kW;^[116] the Mitsui O.S.K. Lines have performed a DFP demonstration on the power generation engine of an ocean-going ship using C Heavy Oil (1% S max.) reporting 80% PM reductions,^[117] and engines up to 6000 kW have been tested with DPFs.^[65] Specific BC controls on ship engines have been reported at 95% to 99.7%.^[65, 111, 115] Many reports suggest that the effectiveness of DPFs is severely reduced as fuel impurities increase, thus making DPF application to HFO combustion a significant challenge.^[112, 114]

3.8.3 Diesel oxidation catalysts (DOCs)

Diesel oxidation catalysts (DOCs) are commonly used in the on-road transportation sector. The technology utilizes precious metals on a honeycomb structure, through which the exhaust is passed to oxidize the exhaust components to less harmful species.^[118] PM reductions of 20% to 40% have been reported; however, this reduction is specific to particulate organic matter and has little effect on BC.^[118]

3.8.4 Selective catalytic reduction (SCR)

Selective catalytic reduction (SCR) is an exhaust treatment that reduces NO_x concentrations significantly. The technology is applied in the marine sector. There is sparse evidence that BC reductions can occur with SCR (up to 35%)^[138] while other studies show no evidence of PM reductions.^[119, 120]

3.8.5 Exhaust gas recirculation (EGR)

Exhaust gas recirculation (EGR) is an exhaust treatment that reduces NO_x emissions that, in combination with an internal scrubber, have an effect on removal of particles (this is assessed in section 3.8.6). The recirculation in itself does not reduce BC and it may in fact increase the build-up of soot.^[121]

3.8.6 Exhaust gas scrubbers (EGS)

Exhaust gas scrubbers have been developed for marine engines as an option to reduce exhaust SO₂ emissions to IMO limits in emission control areas (ECAs) while still using HFO. Scrubbers can use seawater or freshwater to scrub the exhaust to remove gas and particle pollutants. Freshwater scrubbers require an alkaline reactant to effectively remove the acidic sulphur compounds of the exhaust while seawater is sufficiently alkaline to achieve this removal. Dry exhaust gas scrubbers are also in commercial production, and remove SO₂ via chemical absorption to calcium hydroxide. Lack and Corbett^[10] and Corbett *et al.*^[65] have reviewed the efficacy of marine exhaust seawater scrubber (SWS) for removal effectiveness of PM and BC. While PM removal rates often exceed 75% it is apparent that PM removal rates are dependent on particle size and water uptake ability. High sulphur fuels (e.g. HFO) produce hygroscopic PM that can associate with BC, and increase the removal of BC to 50% to 75%. Removal of BC in low sulphur fuel is found to be 20% to 55%. Figure 8 in Lack and Corbett^[10] shows the BC removal efficiency for SWSs for both high and low sulphur fuels. Dry exhaust gas scrubbers also claim PM removal^[122] with one manufacturer reporting PM removal efficiencies of 98%.^[123] It is not known from these reports whether there is an effective removal of BC, although claims that the ultrafine particles are removed effectively have been reported.^[124] The further discussion is limited to SWS systems, though it is assumed that PM removal for seawater and freshwater scrubbers are equivalent.

Table 8 – Summary of Exhaust Treatments as an abatement option (nr: not reported)

Abatement measure	↓CO ₂ % low mid high	↓BC % low mid high	↓NO _x	↓SO _x	Technology maturity	Uptake time	Remarks	Ref.
Electrostatic precipitators	–5 nr nr	60 nr 80	N	N	OS	IN	Size, Commercial availability for ships	[106-110]
Diesel particulate filters	–1 –4 –6	70 85 99	N	N	DE	IN	Commercial availability for ships. Requires low sulphur fuel.	[65, 97, 112–114]
Diesel oxidation catalysts	nr nr nr	nr 0 nr	N	N	CF	IN	Often combined with DPF	[111, 112, 118]
Selective catalytic reductions	nr nr nr	0 nr 35	Y	N	CM	IM		[119, 120]
Exhaust gas recirculation	nr nr nr	nr 0 nr	Y	N	CF	IN	May increase BC soot build-up reported	(39, Pers Com Man)
Scrubbers – high sulphur	–1.5 –3 –5	50 nr 70	Y	Y	CM	IM	Unit cost. Fuel S regulation motivation.	[10, 65]
Scrubbers – low sulphur	–1.5 –3 –5	20 nr 55	Y	Y	CM	IM	Unit cost. Fuel S regulation motivation.	[10, 65]

3.9 Summary of data sources and sampling protocols for BC abatement

As mentioned in sections 2.1, 2.2, and 2.3, there are a number of different sources of data used to identify or infer BC reductions. These included fuel efficiency improvements and/or CO₂ reductions, measurements of bulk and size resolved PM, and measurement of BC, or BC equivalents. Table 9 shows which data sources were used for each of the abatement technologies. Where bulk PM measurements were used, the detailed information suggests that BC reductions are at least as high as the PM reductions due to the PM reduction mechanism affecting all PM and BC.

Table 9 – *BC abatement option and BC reduction data source*

Abatement measure	CO ₂ /fuel efficiency	Size selected PM	Bulk PM	BC
EEDI 2020	✓	x	x	x
EEDI 2025	✓	x	x	x
EEDI 2030	✓	x	x	x
Slide valves	✓	x	✓	x
De-rating	✓	x	x	x
Slow steaming – no de-rating	✓	x	x	✓
Slow steaming – de-rating	✓	x	x	x
Colloidal catalyst	x	x	x	x
Water-in-fuel emulsion	✓	x	✓	✓
HFO – distillate	✓	x	x	✓
Biodiesel – 100%	✓	x	✓	✓
Biodiesel – 20%	✓	x	✓	✓
LNG	✓	x	✓	x
MeOH/DME	x	x	✓	x
Nuclear	✓	x	x	x
Electrostatic precipitator	x	✓	x	x
Diesel particulate filter	x	x	✓	✓
Diesel oxidation catalyst	x	x	✓	✓
Selective catalytic reduction	x	x	✓	✓
Exhaust gas recirculation	x	x	✓	x
Scrubbers – high sulphur	x	✓	✓	✓
Scrubbers – low sulphur	x	✓	✓	✓

Although 100% biodiesel is superior compared to 20% biodiesel, the former option is not considered feasible given limitations in biodiesel supply. Slide valves are already standard on new vessels but is a retrofit option on existing ships.

Where abatement options were assessed via a particle sampling method (e.g. size selected, bulk PM or BC measurement) the used sampling protocols were noted; see table 10. Some recent discussions at the IMO have seen recommendations for the use of a specific ISO protocol to measure ship emissions.^[41]

The summary presented in table 10 reveals that the majority of data presented here, whether from industry reports, peer reviewed literature or elsewhere, contain unreported information on the instrumentation and sampling protocols used. Peer reviewed research often utilized the ISO 8178 protocol,^[125] which was not recommended by Norway within IMO correspondence.^[41] A number of studies used atmospheric sampling where dilution is much higher than any sampling protocol used for emissions testing in a laboratory. Insufficient dilution has been shown to have an effect on emissions measurement.^[e.g. 84] Some other standard engine test cycles were also used. Although a standard protocol such as ISO 8178 or ISO 9096 would be preferable, the current lack of data on particle emissions from ships necessitates the judicious use of data from as many sources as possible. The summary presented below provides context for further discussions on future sampling efforts (i.e. whether a common protocol, or equivalent alternatives, should be implemented).

Table 10 – BC abatement option and measurement details

Reference	Abatement technology	Measurement type (PM, BC, size)	Sample protocol/method
[66]	Slide valves	Unknown (PM)	Unknown
[67]	Slide valves	Unknown (PM)	Unknown
[126]	Slide valves	Unknown (PM)	Unknown
[127]	Slide valves	Unknown (PM, BC)	Unknown
[113]	DPF	Unknown (PM)	Unknown
[112]	DPF	Unknown (PM)	Unknown
[114]	DPF	Unknown (PM)	Unknown
[116]	DPF	Unknown (PM)	Unknown
[117]	DPF	Unknown (PM)	Unknown
[111]	DPF	Smoke meter (BC)	Peer reviewed
[115]	DPF	Filter mass (PM) TOA* (BC)	Peer reviewed, ISO 8178-4, Code of Federal Regulation, Title 40-80, 86
[65]	DPF	Unknown (PM)	Unknown
[10]	Scrubbers	TOA (BC), filter mass (PM), size (PM)	New EU Driving Cycles, Dilution Tunnel
[65]	Scrubbers	Size (PM), mass (PM)	Unknown
[123]	Scrubber	Unknown (PM)	Unknown
[106]	ESP	Filter mass (PM)	Unknown
[107]	ESP	Mass, number (PM)	Unknown
[108]	ESP	Mass, size (PM)	Unknown, peer reviewed
[109]	ESP	Mass, size (PM)	Unknown, peer reviewed
[125]	SCR	TOA* (BC)	ISO 8178
[57]	LNG	Unknown	Unknown
[98]	LNG	Mass (PM)	Unknown, review article
[96]	LNG	Mass (PM)	Unknown, CBD and Brawnschweig Testing Cycles
[100]	MeOH/DME	Number (PM)	Unknown
[92]	Biodiesel	Mass (PM)	Unknown, peer review article
[57]	Biodiesel	Unknown	Unknown
[90]	Biodiesel	Filter absorption (BC)	ISO – 8178
[94]	Biodiesel	Filter mass (PM), size (PM)	ISO – 8178-1
[10]	HFO	Filter, TOA, filter absorption, photoacoustic (BC)	ISO – 8178, Atmospheric Dilution, Increased Dilution Tests, unknown
[80]	HFO	TOA* (BC)	ISO-8178
[10, 79, 80]	Slow steaming	Filter, TOA, filter absorption, photoacoustic (BC)	ISO – 8178, 9096, 10054, 11614, Atmospheric Dilution, unknown
[85, 128]	WiFE	Unknown	Unknown
[86, 129]	WiFE	Unknown	Unknown
[87]	WiFE	Smoke number (BC)	Unknown

* TOA: Thermal-Optical Analysis

4

Short-list selection of BC abatement options

The long list of BC abatement options was reduced to a selection of the highest-probability technologies using a set of objective criteria. It is recognized that in addition to the BC abatement potential, there are other factors that will improve the acceptance of a technology as an abatement option. These include changes in CO₂, NO_x, and SO_x emissions due to the technology, current commercial availability, and time to implementation.

Ranking: criteria for abatement potential

BC abatement: Each 10% reduction (or increase) in BC emissions due to the abatement technology was assigned 1 (or –1) point. For example, a 30% reduction in BC was assigned 3 points.

CO₂ abatement: Each 10% reduction (or increase) in CO₂ emissions due to the abatement technology was assigned 1 (or –1) point. For example, a 10% increase in CO₂ was assigned –1 point.

NO_x abatement: NO_x abatement is not a primary consideration for this project. Whether the specific BC abatement technology changes NO_x concentrations will be of secondary importance. If a BC abatement technology reduces NO_x emissions, produces no change or increases NO_x emissions, the abatement technology was assigned 1, 0 or –1 point respectively. This assignment indicates that the NO_x abatement is an order of magnitude less important than BC reduction.

SO_x abatement: SO_x abatement is not a primary consideration for this project. Whether the specific BC abatement technology changes SO_x concentrations will be of secondary importance. If a BC abatement technology reduces, produces no change or increases SO_x emissions, the abatement technology was assigned 1, 0, or –1 point respectively. This assignment indicates that the SO_x abatement is an order of magnitude less important than BC reduction.

Technology maturity: The commercial availability of a particular BC abatement technology will have an impact on the ability for successful uptake. The five technology maturity criteria outlined in section 2.6 are assigned points of 0 through 4, with the most mature technology receiving 4. This indicates that technology maturity is only approximately 50% of the importance of BC abatement.

Technology uptake time: The time required for implementation of the technology will impact the ability for successful uptake. The uptake time includes the time required for retrofits of current technology, newbuilds of ships, or design and commercialization of immature technology. The five technology uptake criteria outlined in section 2.7 are assigned points of 0 through 4, with the fastest implementation time receiving 4 points. This indicates that technology maturity is only approximately 50% of the importance of BC abatement.

This process was carried out for the mid ranges of abatement potential for BC and other air emissions, which resulted in the short-list of abatement technologies. The process was also carried out for the low and high ranges for BC abatement potential, i.e. utilizing the LOW|MID|HIGH abatement potentials for each technology shown in tables 1 to 8 (not shown).

A summary of the BC abatement options score chart is presented in table 11.

Table 11 – *Ranking of BC abatement options as a weighted points summary including other air emission reductions or employing only BC reduction points, technology availability and implementation*

Abatement measure	All air emissions	Black Carbon only
EEDI 2020	11	8
EEDI 2025	12	8
EEDI 2030	16	9
Slide Valves	12.5	10.5
De-rating	9.5	7.3
Slow steaming – no de-rating	0	0
Slow steaming – de-rating	12.4	8.5
Colloidal catalyst	0	0
WiFE	17	15
HFO – distillate	14.9	13.2
Biodiesel – 100%	10.5	11.3
Biodiesel – 20%	6.8	7
LNG	20.6	16.4
Nuclear	0	0
Electrostatic precipitator	9.8	10
Diesel particulate filter	13.1	13.5
Diesel oxidation catalyst	0	0
Selective catalytic reduction	0	0
Scrubbers – high sulphur	15.7	14
Scrubbers – low sulphur	13.5	11.8

The rankings of abatement technologies when considering BC compared to all air emissions are only slightly different when omitting EEDI, as it is not feasible as a retrofit option. The result is mainly affected by how high 100% biodiesel and electrostatic precipitators are on the top 10 list (see ranking below). The objective was to identify six technologies for consideration for feasibility and costing, and the consolidated list does not include 100% biodiesel, electrostatic precipitators and scrubbers for low sulphur applications. Since slow steaming is voluntarily employed in the industry, this technology was included whereas slide valves were not, although the latter forms part of the WiFE technology.

Table 12 – *The top 10 abatement technologies ranked by including all air emission parameters or only Black Carbon. Final column shows the consolidated list of six abatement technologies*

All air emission parameters	Black Carbon only	Consolidated list
1. LNG	1. LNG	1. LNG
2. Water-in-Fuel Emulsion	2. Water-in-Fuel Emulsion	2. Water-in-Fuel Emulsion
3. Scrubbers – High Sulphur	3. Scrubbers – High Sulphur	3. Scrubbers
4. HFO – Distillate	4. Diesel Particulate Filter	4. Diesel Particulate Filter
5. Scrubbers – Low Sulphur	5. HFO – Distillate	5. HFO – Distillate
6. Diesel Particulate Filter	6. Scrubbers – Low Sulphur	6. Slow Steaming – De-Rating
7. Slide Valves	7. Biodiesel – 100%	
8. Slow Steaming – De-Rating	8. Slide Valves	
9. Biodiesel – 100%	9. Electrostatic Precipitator	
10. Electrostatic Precipitator	10. Slow Steaming – De-Rating	

The top six abatement technologies from the mid range abatement potential are presented in full in table 13. These abatement technologies are evaluated for BC abatement costs in section 5.

Table 13 – Summary of the six technologies for the short-list BC abatement option

Abatement measure	↓CO ₂ %	↓BC %	↓NO _x	↓SO _x	Technology maturity	Uptake time	Remarks	Ref.
EEDI ¹	30	30	Yes	Yes	n/a	LT	Required due to regulation; newbuilds, >400 tonnes	[36]
Slow steaming: with de-rating	18.5	15	Yes	Yes	CM	IN	New engine needed	[10, 62, 72, 76, 78]
Water-in-fuel emulsion	0	70	Yes	Yes	CF	IM		[62, 65, 85, 87]
HFO – distillate	7	52	No	Yes	CM	IM	Fuel cost/availability	[10]
LNG	22.5	93.5	Yes	Yes	CF	IN	Engine/fuel storage retrofit; port supply of LNG; fugitive emissions	[62, 96–98]
Diesel particulate filters	–3.5	85 ²	No	No	D	IN	Commercial availability for ships; requires low sulphur fuel	[65, 97, 112–114]
Scrubbers – high sulphur	–3	60	Yes	Yes	CM	IM	Unit cost: fuel S regulation motivation	[10, 65]

¹ The EEDI is not included in the BC abatement cost assessment.

² The 85% is a mid range between the minimum and maximum reductions reported for LSFO. It happens to also correspond to the reductions reported for the HFO trial; however, this is coincidental.

5

Cost and feasibility of BC abatement technologies

The full technical and cost-analysis report is included in appendix E, which evaluates the cost effectiveness of the short-list of identified market-available BC abatement measures. A detailed summary of the report is provided in this section. The base example is a tanker (Aframax), for which both retrofit and newbuilding installation are provided.

For comparison, the installation costs on a range of ship types – tanker, container, bulker carrier, gas carrier, passenger ship, offshore supply vessel (OSV)/anchor handling tug supply (AHTS) and tug – are provided for vessels with similar engine size (10 MW) and vessels of approximately the same physical size vessel, i.e. with comparable docking costs (tugs and OSV)/AHTS excluded). The data is given in detail in appendix E.

5.1 Abatement technology case by case

The selected abatement measures are applied to the base case, Aframax Tanker, as listed in appendix E, where the calculated capital investment cost and application to seven vessels are summarized. Of the selected vessels, five are of similar tonnage but with very different power requirements due to application and speed requirements. Two vessels are smaller. The procedure to estimate the cost for each abatement measure was to utilize quotes from manufacturers, where it was concluded that there is a linear relationship between the price of the equipment and the power of the main engine, except for the EEDI, which is dependent on other parameters as well. Estimated uncertainty in these estimates is 10% to 20%. The quotes were converted to a US dollar cost per kilowatt hour (USD/kWh) and used to scale to the relevant vessel.

The capital investment of the abatement measures is approximately 80% to 90% of the total retrofitting cost, which minimizes the costs associated with installation location (labour, etc.). Some of the retrofitting cases were estimated to take up to 40 days, and so the charter rates of each vessel type for this lost time were also taken into consideration. Reduced costs are obviously associated with the installation of the abatement measures at the vessel newbuild stage, and the reduction potential in capital expenditure (CAPEX) is between 40% to 60% depending on off-hire rates and installation time. During the vessel design phase for a newbuild, many of the smaller modifications to the standard design can be absorbed into the contract price. The cost difference between newbuilding and retrofitting is illustrated in appendix E. The CAPEX calculations are based on the installed Shaft power of the vessel at 100% MCR.

Consideration for the additional operating costs per day has also been taken into account. The additional operating costs per day are chosen due to the fact that each abatement measure has a varying degree of energy requirement, which is dependent on the abatement measure (appendix E). The abatement measures do not require additional crew competencies except for LNG installation, where an estimated 10% additional crewing cost is required, due to the complexity and safety requirements of the systems. The reason for not including the vessels' individual operating expenditure (OPEX) is simply that the different vessels, owners and managers use different nationalities of crew, which could influence the OPEX considerably. Crewing costs are often approximately 50% of the total OPEX of a vessel, depending on the complexity and flag of registration. The OPEX calculations are based on 90% MCR.

5.2 Slow steaming – with de-rating

Slow steaming became popular within the shipping industry at the end of 2007, mainly with container vessel owners and operators, as a consequence of drastically dropping charter rates at the beginning of the global financial downturn. Vessels were instructed by owners to reduce main engine load to approximately 40%

MCR, which decreased the speed by approximately 20%. Summarized calculations of an average fuel oil cost (FOC) savings of approximately 42% without a de-rated engine and 45% with a de-rated motor are shown in table 14 below.

Table 14 – *Slow steaming (40% MCR) without and with de-rated engine*

	Shaft power (kW)	Speed (knots)	Distance (nautical miles)	Time (hours)	Total fuel consumption (ton)	Fuel oil savings (%)
90% MCR (kW)	14,256	15.0	10,000	667	1,730	0%
40% MCR (kW) without de-rating	6,336	11.4	10,000	877	1,012	42%
40% MCR (kW) with de-rating	6,336	11.4	10,000	877	951	45%

From January 2010, owners started to investigate super-slow steaming down to below 35% MCR and as low as 10% MCR. Engine makers were initially hesitant due to the lack of experience, but in June 2011 MAN Diesel issued a service letter (SL11-544 MTS) permitting owners to reduce engine load down to 10% MCR, though with certain recommendations. Several problems may arise from low load operation, e.g. loss of main engine turbocharger and propeller efficiency, hull fouling and economizer soot build-up.

Electronic engines (ME, ME-B and RT-FLEX) are more flexible for slow steaming, therefore it is recommended to convert all mechanical injection main engines to electronically controlled engines.

In the 2012 Danish initiative Green Ship of the Future in Copenhagen, MAN Diesel presented a vessel emissions study,^[130] in which the conversion cost of the MT Nord Butterfly from an MC engine (mechanical injection) to an ME-B engine (electro hydraulic, common rail injection) was estimated. The conversion was from a 6S50MC-C (9,480 kW) motor to a 6S50ME-B motor with the same effective power. With our experience from MAN Diesel retrofits it is possible to calculate a cost per kW to scale the CAPEX to the specific vessels (see appendix E). If a vessel already has an electronic engine installed, the CAPEX will be reduced approximately 45% to 50%.

Table 15 – *Green Ship of the Future: Vessel Emission Study (Copenhagen 2012)^[130]*

	Amount	Unit
NORD Butterfly ME-B Conversion	9,480	kW
CAPEX	800,000	USD
Cost for ME-B conversion	84	USD/kW

5.3 Water-in-fuel emulsion (WiFE)

In water-in-fuel emulsions (WiFE), water is added continuously to the fuel supply and a homogeneous mixture is achieved by mechanical measures. When WiFE is used it can be observed that the specific fuel oil consumption (SFOC) generally increases for the larger additions of water. This is due to the energy required to heat up the injected water to its saturation temperature, subsequent evaporation at the saturation temperature, and further super-heating to the temperature in the combustion zone. In previous work, the SFOC penalty at 30% vol. added water is estimated to be approximately 2% when considering evaporation and super-heating only. It should be noted that the water may contribute with work in the expansion process, thereby reducing the actual SFOC penalty, and that little is known about the corrosive effects from the water on the fuel system and other machinery related to the fuel system.^[137]

To retrofit a WiFE system to a standard engine, the following components need to be installed or replaced:

- A homogenizer unit, which heats the water and mixes it with fuel to form an emulsion prior to injection, is to be installed. CAPEX is estimated to USD 400,000 excluding retrofitting costs on a 40,000 kW engine.^[131] To this a 20% price increase from 2006 to 2012 is assumed based on 3.5% inflation per year, which gives an USD/kW estimate of approximately USD 13/kW. If retrofitting costs are included, but excluding off-hire, the average cost is USD 27/kW. On the Aframax Tanker base case a retrofit time of 20 days with an off-hire rate of USD 20,000/day is assumed, which increases the cost to USD 52/kW.

- A possible increase in freshwater (FW) storage capacity on board, as a standard FW generator cannot keep up with the FW consumption of the WiFE system. Thus, additional FW is to be stored on board. FW consumption is dependent on power requirement and not ship size. A large, slow steaming Aframax tanker will consume considerably less FW compared to a container vessel of the same size sailing at full speed. Average FW generation on board a commercial cargo vessel is 25 MT/day. The cost of FW water depends on many variables – trading routes, FW generation on board and FW consumption on board (apart from WiFE). As this cost also has little influence on the CAPEX or OPEX, it is therefore not included in the calculations.
- Replacement of the standard fuel valve (fuel injector) with slide fuel valves is needed due to the more efficient atomization of the fuel and to optimize the combustion. The cost of the new slide fuel valves is included in the total cost as per table 16.

Table 16 – MAN Diesel: WiFE cost overview^[132]

	Amount	Unit
Engine power	40,000	kW
Total WiFE unit cost and slide fuel valves	500,000	USD
Cost per kW (excl. retrofit)	13	USD/kW
Cost per kW (incl. retrofit, excl. off-hire)	27	USD/kW
Cost per kW (incl. retrofit and off-hire)	52	USD/kW

5.4 Heavy fuel oil (HFO) – distillate

A fuel switch to distillate fuel from heavy fuel oil is a simple alternative to achieve compliance with current and forthcoming IMO emissions regulations on maximum allowable sulphur content in the fuel oil. There are two main challenges when running on distillate fuels, e.g. MGO: fuel viscosity and main engine cylinder lubrication.^[133]

- The fuel systems for engines, boilers and other machinery required to comply with IMO regulations are recommended to have a cooler or chiller arrangement fitted, to meet the fuel viscosity requirements for safe operation of the engine's fuel system. Vessels in the future will probably not experience problems running without a chiller due to the fact that engine and pump makers are designing their equipment to run on the lower viscosity fuels, but it is not recommended due to the increased wear on fuel systems. Cooling of the MGO is a not a straightforward solution, since several parameters should be considered before deciding the appropriate method of cooling, e.g. SFOC, duration of time using MGO, pumps and engine fuel system specification, and age.
- There is a correlation between low sulphur fuels and BN or TBN (Base Number). Thus, when low sulphur fuels with <1% sulphur are used, the cylinder lubrication rate is lowered to the minimum dosage recommended by engine makers (when using an oil for HFO (e.g. BN70)). In this configuration the cylinder liner would be overadditivated. Therefore, engine makers recommend changing to low BN cylinder lube oils of BN 40-50 when fuels below 1% sulphur are used for prolonged periods of time. Automatic cylinder feed rate regulating systems, e.g. the Alfa Lubricator, are recommended on newer engines in order to regulate the dosage automatically during different engine loads.^[133]

A chiller unit costs approximately USD 70,000 for the Aframax Tanker base case, which represents a USD 4/kW exclusive installation cost. The calculated cost inclusive installation is USD 13/kW; however, that does not include the expected 10 off-hire days. This chiller unit price could vary, depending on which system and maker are chosen.

Table 17 – MGO chiller unit cost

	Amount	Unit
MGO chiller unit cost (excl. inst.)	70,000	USD
MGO chiller cost (excl. inst.)	4	USD/kW
MGO chiller cost (incl. inst.)	13	USD/kW

5.5 LNG/DME

Liquefied natural gas (LNG) is natural gas stored as liquid at -162°C . The predominant component is methane with some ethane and small amounts of heavy hydrocarbons. LNG as a fuel for marine propulsion and power generation has been common with 4-stroke engines as a dual fuel system for LNG tankers. In a dual fuel system, boil-off gas is used as fuel on loaded voyages and HFO on the ballasted voyage. Two-stroke LNG-powered engines have been in operation only as land-based, stationary engines for power generation running at a constant load. In contrast, marine engines have variable loads and restricted space for LNG fuel tanks. Both MAN Diesel and Wartsila have announced that they have LNG-powered two-stroke engines available for marine propulsion.

Vessel engine load depends on the vessel's operational characteristics. Generally, larger vessels such as bulkers, tankers and container vessels operate using two-stroke LNG engines with constant load and RPM for the majority of their journey. Variable loads on engines result from vessels with shorter journey times such as cruise liners, supply vessels and tugs. These vessels use four-stroke dual fuel engines with diesel electric propulsion units for better efficiency. Exhaust gas emissions (SO_x and PM) from the combustion of LNG are negligible, while CO_2 emissions are reduced (when the efficiencies from the tank to the propeller are considered) because LNG contains less carbon than do fuel oils.

There are two main disadvantages to LNG retrofits: LNG requires at least double the fuel tank volume of fuel oils, which is a challenge for vessels with limited or no deck space, e.g. container vessels, cruise liners and bulk carriers. Cost estimates for LNG fuel tanks range from USD 1,000/m³ to USD 5,000/m³. MAN Diesel advised that an LNG retrofit is not possible on a two-stroke mechanically controlled fuel system, thus a conversion to an electrohydraulic common rail fuel system (ME-B) is required. There is a cost savings of approximately 20% if the vessel has an electrohydraulic common rail fuel system (ME-B, ME-C or RT-Flex) installed prior to LNG retrofit.

The following costs are involved with LNG installation on the Aframax Tanker base case:

Table 18 – LNG conversion estimates

	Amount	Unit
Cryogenic plant	1,500,000	USD
LNG tank cost	1,000	USD/m ³
LNG tank capacity	2,000	m ³
LNG machinery conversion	42	USD/kW
NORD Butterfly ME-B conversion*	9,480	kW
CAPEX*	800,000	USD
ME-B conversion cost*	84	USD/kW
Total Engine LNF conversion cost (excl. inst.)	126	USD/kW
Total Engine LNF conversion cost (incl. inst.)	455	USD/kW

* Green Ship of the Future: Vessel Emission Study (ME-B conversion)^[130]

Table 19 – Fuel consumption penalties

	Amount	Unit
Pilot fuel consumption penalty	2.0%	kg/kWh
Cryogenic pump fuel penalty	1.2%	kg/kWh
Total penalty	3.2%	kg/kWh

5.6 Diesel particulate filters (DPF)

The diesel particulate filter (DPF) system comprises silicon carbide ceramic fibres and a self-cleaning mechanism. The filter collects particulate matter (PM) as exhaust gas is forced through it and is very efficient at the removal of PM and BC. The self-cleaning element automatically combusts and eliminates PM build-up in the filter. This allows for continual operation without clogging the filter and requires no maintenance by seafarers. The use of particle filters in inland waterway vessels and highway trucks has been very successful.

The Japanese shipping line MOL started preliminary tests of a diesel particulate filter on a two-stroke engine in 2010. A demonstration test was initiated in November 2011^[134] and in February 2012 the DPF system had operated smoothly for more than 500 hours. With research support from the Japanese Classification Society (ClassNK), they have jointly developed a DPF system for marine diesel engines, which run on C heavy oil.

The MOL test is scheduled for about one year (operating time about 4,000 hours) to verify the system's PM collection performance. After that its durability will be assessed. The additional energy penalty due to exhaust back pressure is estimated to be approximately 0.4% of shaft power.^[135] The space requirements of these filters (2 to 3 times engine volume)^[135] introduce considerable cost.

A paper by Eelco den Boer, "Emissions from the Legacy Fleet",^[135] estimates the installation cost of DPF on inland waterway vessels. The estimated CAPEX cost was reported to be EUR 50/kW \approx USD 63/kW and the CAPEX including installation costs for a typical retrofit case to EUR be 110/kW \approx USD 139/kW (EUR to USD exchange rate \approx 1.26).

Table 20 – Cost of DPF

	Amount	Unit
CAPEX DPF (excl. inst.)	63	USD/kW
CAPEX DPF (incl. inst.)	139	USD/kW

5.7 Scrubbers – high sulphur

Trials of exhaust gas scrubbers have been conducted since 2006, and the system selected for this analysis has an open loop (seawater mode) system and a closed loop (internal freshwater mode) system. In a closed loop, freshwater is recycled, into which sodium hydroxide (NaOH) is continuously added in order to balance pH to a slightly alkaline value (required for optimal scrubbing operation). The closed loop is used for special areas or coastal waters where discharge water is restricted.

Scrubber consumables would result in FW mode. NaOH can be supplied as a 50% solution by tanker trucks at most major ports around the world as it is used in many industries to produce paper, soap, detergents, etc. The vessel can also be supplied with large 5 m³ IBC containers with heat insulation due to volatility from temperature change. NaOH flakes or pellets can also be supplied, in which case the crew will have to manually blend the dry product with water on board.

The average costs of the equipment, table 20, in USD/kW can be used to scale the price of the equipment linearly according to the power requirement for the specific vessel, as found in appendix E. A typical newbuilding cost would be USD 330/kW, excluding off-hire and drydocking, and for a retrofit case USD 368/kW, including off-hire and drydocking.

Table 21 – Scrubber cost

	Amount	Unit
Scrubber cost (excl. off-hire and drydocking)	330	USD/kW
Scrubber cost (incl. off-hire and drydocking)	368	USD/kW

Table 22 – RETROFIT: CAPEX in USD of retrofitting vessels of different type and engine size, but comparable physical dimensions to provide similar drydock costs.
Shaft power is given in kW @100% MCR

		EEDI (de-rating)	De-Rating	Emulsion	LNG	HFO-distillate	DPF	Scrubber	
1	Aframax	16,000	2,210,000	2,210,000	810,000	8,080,000	410,000	1,410,000	5,880,000
2	Container	85,000	9,730,000	9,730,000	2,970,000	45,630,000	1,500,000	6,160,000	29,240,000
3	Bulk Carrier	15,000	2,050,000	2,050,000	740,000	8,490,000	370,000	1,310,000	5,490,000
4	Gas	22,000	3,110,000	3,110,000	1,160,000	12,600,000	580,000	1,990,000	8,160,000
5	Passenger	75,000	9,330,000	9,330,000	3,120,000	41,250,000	1,570,000	5,930,000	26,540,000
6	OSV/AHTS	16,000	2,660,000	2,660,000	1,110,000	9,690,000	560,000	1,710,000	6,330,000
7	Tug	6,100	910,000	910,000	360,000	3,560,000	180,000	580,000	2,310,000

Table 23 – NEWBUILD: CAPEX in USD of retrofitting vessels of different type and engine size, but comparable physical dimensions to provide similar drydock costs.
Shaft power is given in kW @100% MCR

		EEDI (de-rating)	De-Rating	Emulsion	LNG	HFO-distillate	DPF	Scrubber	
1	Aframax	16,000	1,610,000	1,610,000	410,000	7,280,000	210,000	1,010,000	5,280,000
2	Container	85,000	8,530,000	8,530,000	2,170,000	44,030,000	1,100,000	5,360,000	28,040,000
3	Bulk Carrier	15,000	1,510,000	1,510,000	380,000	7,770,000	190,000	950,000	4,950,000
4	Gas	22,000	2,210,000	2,210,000	560,000	11,400,000	280,000	1,390,000	7,260,000
5	Passenger	75,000	7,530,000	7,530,000	1,920,000	38,850,000	970,000	4,730,000	24,740,000
6	OSV/AHTS	16,000	1,610,000	1,610,000	410,000	8,290,000	210,000	1,010,000	5,280,000
7	Tug	6,100	610,000	610,000	160,000	3,160,000	80,000	380,000	2,010,000

6 Comparison of abatement technologies

6.1 Introduction to assessments

In this section the effectiveness of the abatement technologies is assessed through their costs both on a generic level and on a ship type level, the latter exemplified with the Aframax example in section 5.

The overall effectiveness of an abatement is calculated as the cost associated with a reduction in BC emissions compared to the base case using MDO as fuel. However, the final assessment of the abatement technologies also considers factors such as those mentioned in sections 3 and 4, in particular the technological maturity, the technology's co-reduction with other regulated air pollutants and the applicability in the Arctic.

The Aframax ship type example

Comparing the different methodologies regarding the costs relative to the benefits is the objective of this section. The costs and benefits, the latter measured as reduced amount of BC, are compared using the Aframax Tanker base case as an example, but the calculation is carried out for other ship types as well, including container, bulk carrier, gas carrier, passenger, offshore supply vessels/anchor handling tug supply vessels and tugs. The calculations for all included ship types are provided in appendix C.

The data is provided in 2012 costs in USD, similar to section 5, but include depreciation and interest rate, remaining lifetime and a given number of operating days per year.

Table 24 – Basic assumptions for cost-benefit assessment

Operating days per year	260
Interest rate	6%
Lifetime year	
Retrofit	10
Newbuilding	30

As mentioned earlier, the base case is a comparison to MDO, since a BC regulation is not expected to be introduced prior to the sulphur regulation in 2020, and no assumptions are made regarding geographical, ship type or timely limitations.

Cost effectiveness of the technologies

The cost effectiveness has been calculated according to the method of Corbett *et al.*^[65] using the same input data as given in section 5 and these results are presented in appendix B. In the model time spent in ECAs or special areas can be modelled. The costs are presented for an all year operation in such areas (6,240 hours).

Table 25 – *Input parameters for cost effectiveness after Corbett et al.^[65]*

Input parameter ranges		Low	Medium	High
° = Average engine load fraction	0.72	–	–	–
Total annual operating hours (h)	6,240	–	–	–
Interest rate	–	4%	7%	10%
BC emissions rate (g/kWh)	–	0.03	0.07	0.17
Time with system engaged (%)	–	100%	100%	100%
Φ = engine power (kW)	–	5,500	10,000	49,504
Fuel prices:	–			
MDO (USD/ton)	–	973	1,041	1,095
HFO (USD/ton)	–	642	659.8	671
LNG (USD/mmBtu)	–	10	10	10

6.2 Comparisons of technologies

6.2.1 Yearly reduction potential for abatement technologies

Base case MDO

The percentage of reductions of BC as estimated in section 3 were recalculated to mass, assuming the base fuel to be MDO.

Table 26 (overleaf) shows the calculated reduction of BC by the short-listed abatement technologies. The emission reduction rates were calculated from percentage reduction as given in table 13 and with 0.07 g BC/kWh as the base case.

Table 26 – Assessment of reduction of BC through abatement technologies in example vessel (14.4 MW)

	No abatement (using MDO and assuming EEDI)			Slow steaming and de-rating			WiFE			LNG		
	Low	Best	High	Low	Best	High	Low	Best	High	Low	Best	High
Reduction (%)	0	0	0	20	50	80	0	30.56	58.33	80	93.5	100
BC emission rate (g/kWh)	0.07	0.07	0.07	0.056	0.035	0.014	0.07	0.049	0.029	0.014	0.005	0.00
BC reduction rate (g/kWh)	0	0	0	0.014	0.035	0.056	0	0.021	0.041	0.056	0.065	0.07
Annual BC emissions (g/y)	3.14E + 06	3.14E + 06	3.14E + 06	2.52E + 06	1.57E + 06	6.29E + 05	3.14E + 06	1.52E + 06	9.10E + 05	6.29E + 05	2.04E + 05	0.00E + 00

	DPF			SWS			FWS		
	Low	Best	High	Low	Best	High	Low	Best	High
Reduction (%)	70	85	90	25	40	50	25	40	50
BC emission rate (g/kWh)	0.021	0.011	0.007	0.053	0.042	0.035	0.053	0.042	0.035
BC reduction rate (g/kWh)	0.049	0.059	0.063	0.017	0.028	0.035	0.017	0.028	0.035
Annual BC emissions (g/y)	9.43E + 05	4.72E + 05	3.14E + 05	2.36E + 06	1.89E + 06	1.57E + 06	2.36E + 06	1.89E + 06	1.57E + 06

6.3 Cost of reducing BC in example vessels

The price for reducing BC with the different abatement technologies is assessed through the BC reduction potential as provided in section 4 and the costs found in section 5. The cost in USD per reduced gram of BC was calculated including CAPEX and OPEX in a standard scenario for the Aframax Tanker example, where an existing vessel has 10 years of remaining trading life and a new vessel has 30 years (for other details see appendix E).

6.3.1 Aframax Tanker 14.4 MW

The estimate for the reduction of BC is shown for the example case (14.4 MW Aframax Tanker as in section 5), with the column showing the reduction based on the best estimate and the bars showing upper and lower ranges of estimates. In absolute amounts, the largest reductions are achieved by moving from HFO or MGO to LNG, or by introducing DPF, since both technologies yield >90% reductions in BC (bearing in mind the lack of experience with DPF in international shipping). The remaining technologies provide 30% to 50% reductions, although the data sets are not strong regarding BC and considerable ranges are seen between high and low estimates, except for the scrubber data.

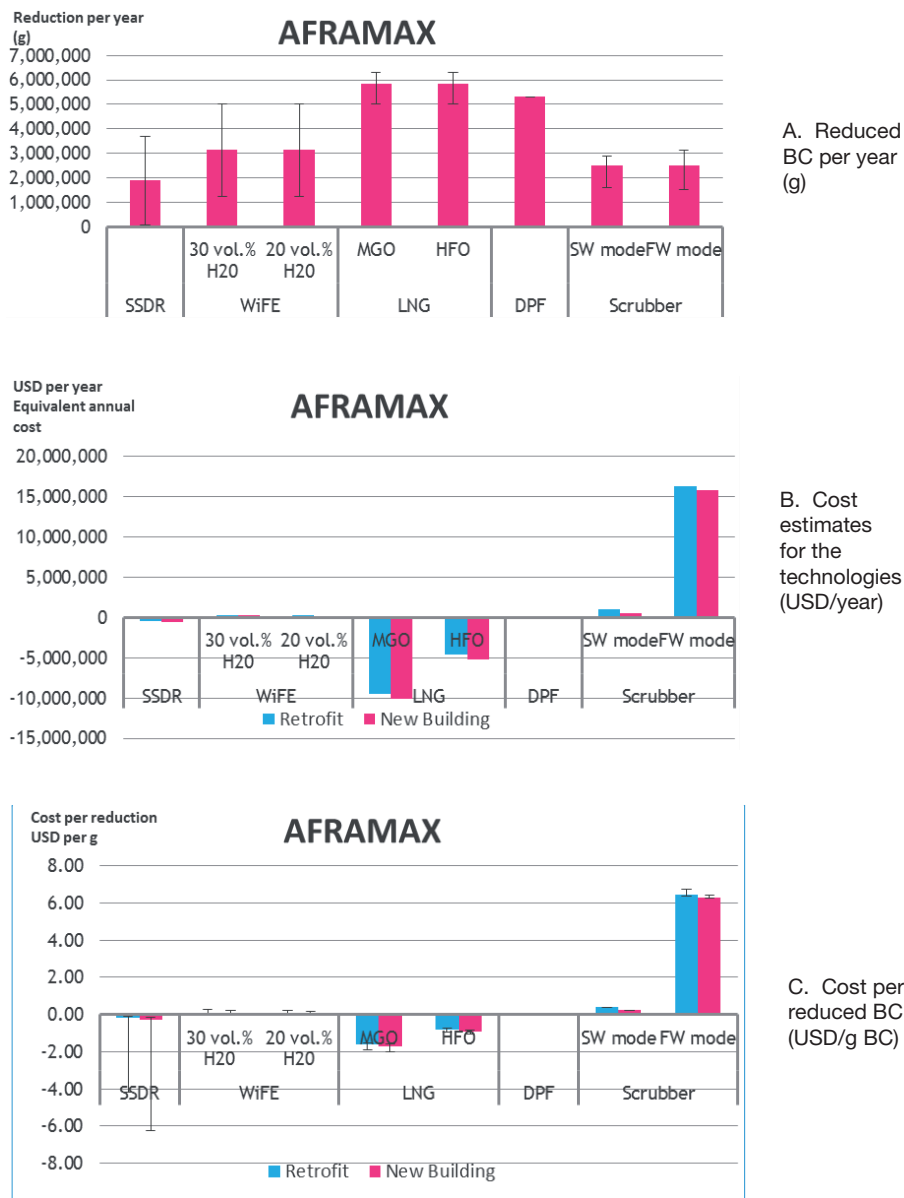

Figure 2: A–C The amount of BC reduced, the cost and the estimated cost effectiveness of the abatement technologies in the example vessel. The cost assessment is given for Retrofit (blue) and Newbuilding (red)

Fuel switch from HFO

The case where a fuel switch from HFO to distillate is introduced in the base case and the reductions are calculated from a base emission of 1.34 g BC/kWh.^[138]

Table 27 – BC reduction with fuel switch from HFO

	HFO → Low sulphur distillate		
	Low	Medium	High
Reduction (%)	30	50	80
BC emission rate (g/kWh)	1.34	1.34	1.34
BC reduction rate (g/kWh)	0.40	0.67	1.07
Annual BC emission (g/year)	8.45E + 07	6.02E + 07	2.43E + 07

The cost efficiency is relatively high, as the estimated cost is approximately USD 0.08 per g reduced BC.

6.3.2 Comparison over range of ship types with 10 MW installed effect

Since the governing factors associated with abatement technology installation and operating costs are related to the installed effect, the overall pattern remains more or less the same across ship types, but nevertheless there are differences mainly related to the installation and off-hire costs for the vessel type.

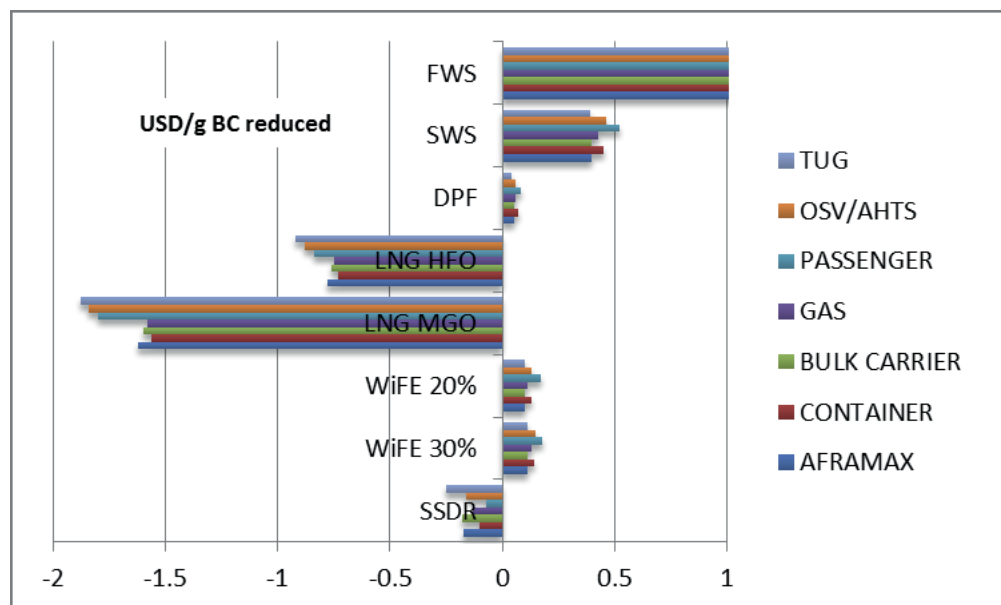

Figure 3: The cost in USD per gram reduced BC emissions for the short-listed abatement technologies over a range of vessels at similar installed effect (10 MW). Upper bars for freshwater scrubber are clustered around 6.5 USD/g BC and omitted for clarity (data from appendix B)

6.3.3 Sensitivity of analysis

The table below provides estimates of the cost effectiveness of BC reduction for the different abatement technologies: slow steaming, water-in-fuel emulsification (WiFE), switching to liquid natural gas (LNG), diesel particulate filters (DPF), seawater scrubbing (SWS) and freshwater scrubbing (FWS).

Table 28 – Cost effectiveness (USD/g BC reduced) in select combinations of the cost of fuel and the interest rate scenarios in High, Medium and Low. Thus, for example, high fuel cost and medium interest rate will be HFC-MIR. Numerical values of MDO costs are the lowest, current and highest MDO prices since March 2009, and the annual interest rates are 4%, 7% and 10%, respectively. All estimates are made for an engine power of 10,000 kW, total annual operating hours of 6,240, use of marine diesel oil (MDO) and an average engine load fraction of 0.72.

Cost effectiveness (USD/g BC reduced)	Base case MFC-MIR	MFC-HIR	MFC-LIR	LFC-MIR	HFC-MIR
Slow steaming	-2.62	-2.60	-2.65	-0.76	-3.16
WiFE	0.07	0.08	0.06	0.05	0.07
LNG	-1.73	-1.7	-1.76	0.26	-2.31
DPF	0.21	0.21	0.21	0.12	0.23
SWS	0.31	0.35	0.28	0.24	0.33
FWS	8.92	8.95	8.89	8.76	8.96

The first observation is that the ranking of the methods in terms of USD/g BC reduced does not change regardless of the cost of fuel and the range of interest rates – except for LNG when MDO fuel price is low and the advantage of the fuel switch to LNG is less pronounced.

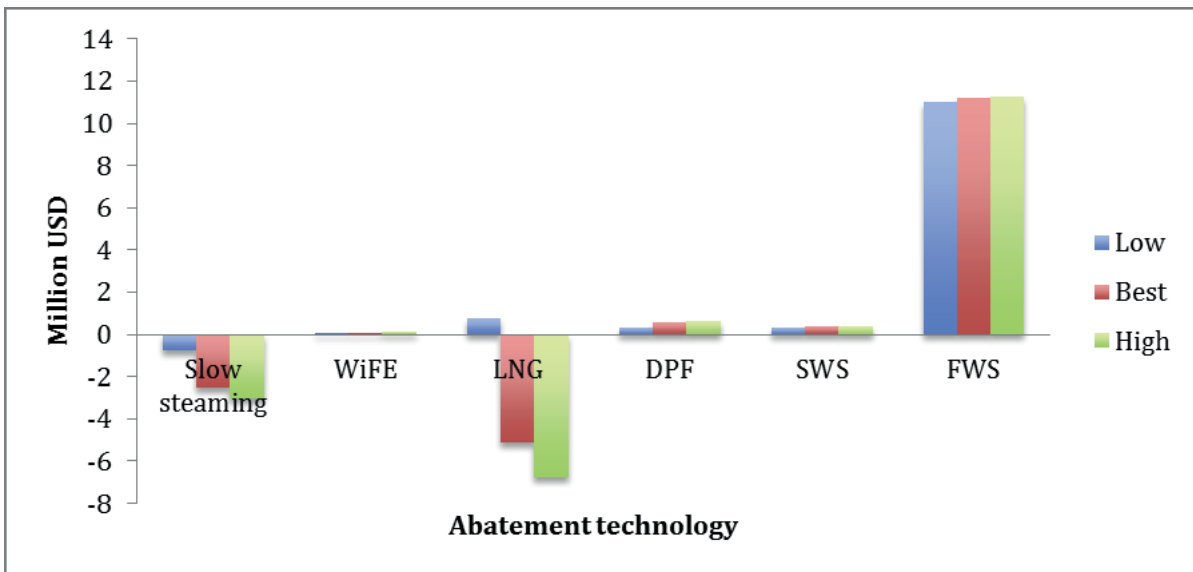

Figure 4: Total costs of the different abatement technologies using the best estimate MDO price of USD 1,011.8 USD/ton, the lowest MDO price of USD 320/ton and the highest MDO price of USD 1,213/ton.

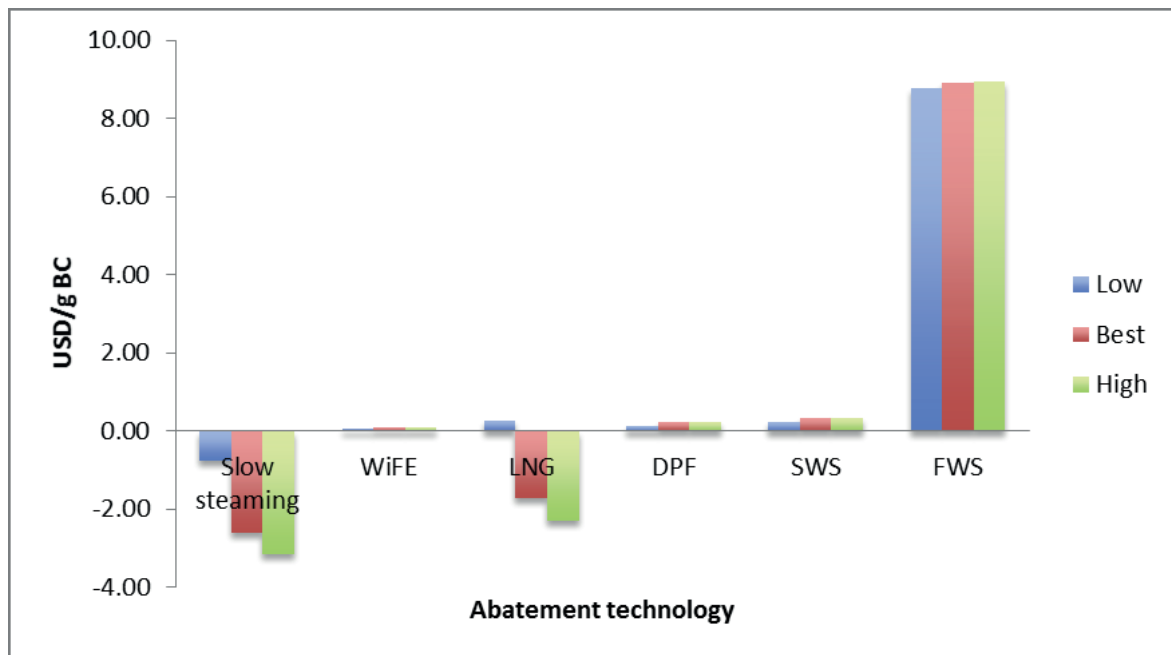

Figure 5: Cost effectiveness of the different abatement technologies using the best estimate MDO price of USD 1,011.8/ton, the lowest MDO price of USD 320/ton and the highest MDO price of USD 1,213/ton.

6.4 Assessment of feasibility

The EEDI, which applies only to new ships, will lead to CO₂ and non-CO₂ emission reductions. Many measures available for improving the EEDI of a new vessel are viable for existing vessels and will undoubtedly form part of the toolbox used to meet the requirements of the Ship Energy Efficiency Management Plan (SEEMP), applicable to all ships. Since the measures taken for an individual vessel regarding EEDI or SEEMP may include a number of options, the possible combinations with the BC abatement technologies are numerous and choices may, to a varying degree, impact one another. Most fuel efficiency measures will reinforce each other in terms of BC reductions; however, some efforts, such as slow steaming without de-rating, will counteract BC reductions from other technologies. Such multidimensional interactions have not been included in the costing exercise, but it has been estimated by DNV that the increased fuel efficiency will amount to 13% in 2030 from EEDI and 9% from SEEMP.^[136]

6.4.1 Slow steaming – with de-rating

Simply reducing vessel speed will not achieve any BC emission reductions, and may in fact increase emissions unless the engine has electronically controlled injection and can adjust to the load. Here, the assessment is done where slow steaming is achieved with de-rating and the technology is actually generating savings of approximately USD 2.6 per reduced g of BC.

Regarding slow steaming, it is obvious that more tonnage is needed to transport the same total cargo volume when travelling at a slower speed. It can be estimated that 15% to 20% more tonnage is needed, although it is currently observed that slow steaming is used to absorb surplus tonnage in the market. Since the estimations on abatement technology are concerned with the comparison of cost associated with the individual vessel, these are not included in the calculations.

As mentioned in section 3, many shipping companies have already pursued slow steaming and many more may do so in order to pursue fuel savings to meet EEDI requirements. Thus, reduction in BC emissions will be achieved through the fuel savings associated with EEDI. Slow steaming may be a preferred option for ships operating on the high seas, but the need for highly adjustable loads in Arctic waters during icy conditions may limit applicability in vessels operating there (particularly with engines with mechanical operation).

6.4.2 WiFE

WiFE produces significant BC reductions with the addition of 20% to 30% water to the fuel. WiFE is an abatement technology with fewer barriers and it provides a less costly reduction in BC at some 5 to 8 cents/g BC reduced. It is market ready and already in use for the purpose of reducing NO_x emissions. It must be kept in mind that many studies of WiFE were carried out with the objective of studying the reduction of nitrogen oxides. PM reductions were often measured albeit with limited direct measurements of BC reductions. Recent work suggests that both MDO and HFO water emulsions can be produced to achieve the NO_x, PM and BC benefits. Although the BC reductions are considered valid only few studies are available to further substantiate the reported fuel cost reductions of 10% or more at 15% to 20% water. To accommodate this uncertainty a sensitivity analysis is performed comparing a 10% fuel reduction scenario with the scenario of 1.5% to 2.0% fuel penalty used in the estimates above.

Substantial savings are associated if 10% SFOC are achieved in a WiFE. The cost of reducing one gram of BC at a 1.5% to 2.0% fuel penalty is 0.08 to 0.10 USD as seen in table 28 whereas the 10% fuel reduction leads to a negative cost of 0.31 to 0.36 USD/g BC, i.e. savings, in the 10 MW Aframax model vessel.

6.4.3 LNG/DME

The use of natural gas as fuel for propulsion of ships is considered attractive in terms of its potential for reduction of SO_x and NO_x, but it has considerable potential for BC reduction also. However, the barriers are high for introduction, since the ships must undergo extensive retrofitting and may lose commercial space on board, in addition to a widespread lack of bunkering facilities. The advantage, besides the reduction of emissions, is a fuel bonus rendering LNG a most cost-effective remedy generating savings of approximately USD 1.7 per gram BC reduced.

If the alternative fuel is MGO, as in ECAs when operating without a scrubber, the use of LNG is very attractive. For HFO, the case is less attractive but still positive. The use of LNG reduces the BC emissions considerably more than a simple switch to distillate fuels, although an LNG estimate using the High estimate will overestimate reality in a dual fuel engine since pilot fuel and lubricants will contribute some 2% BC in practice.

No detailed assessment of DME was performed, since the technology is not yet available beyond the initial test stage. Engine requirements are reportedly similar to LNG, but the use of DME for fuel is less dependent on costly infrastructure.

6.4.4 Diesel particulate filters

The advantage of DPFs is the great efficiency of the exhaust after treatment. Despite the technology's low cost, it suffers from a severe lack of maturity in maritime applications and, more importantly, the experience from land and inland water traffic with DPF is that the abatement technology currently can only be operated on (ultra) low sulphur diesel. Results of an ongoing DPF test on a vessel operated on C Heavy fuel is awaited with interest. The ranking here reflects a situation where DPF can be operated on MDO.

The filters are well known from land-based applications for diesel and low sulphur fuels, but it is an open question as to how marketable the DPFs are in the immediate future in the maritime market. The costs are comparable to abatement with the seawater scrubber solution.

6.4.5 Scrubbers – high sulphur

Scrubbers, in both seawater and recirculation modes, are effective technologies for the reduction of BC. When applying scrubbers on the base fuel case of MDO to reduce BC, this technology is a suitable abatement technology at an approximate cost of 30 cents/g BC reduced. The vessel will often need to operate in freshwater mode close to port and the consumption of sodium hydroxide during this freshwater mode is a major cost that bears negatively on the BC reduction cost. This is a significant drawback, e.g. for tugs. It must be kept in mind that marine scrubbers are designed and developed for the reduction of sulphur oxides when operating on HFO, rather than reduction of BC, and their use in international shipping are expected to vastly expand with the introduction of a stricter sulphur regime in 2020.

The actual economical feasibility of this technology is therefore dependent on the trade pattern of the vessel with the expected operation in the vicinity of ports or in ECAs. Obviously, when scrubbers are required and installed for other reasons, the BC reduction comes as a collateral benefit. Scrubbers for the reduction of BC in low sulphur fuels have not been assessed.

6.4.6 HFO – low sulphur fuel

Significant reductions in BC are achieved when switching from HFO to a lower sulphur fuel, as in the case of distillate fuel. There are studies suggesting that there is no BC reduction or even increases in BC emissions as fuel quality improves, but most studies point to a genuine BC reduction potential, which is corroborated by the experience from land-based diesel engines (see section 3 for the discussion on this).

This is obviously also the case when choosing LNG as the alternative to HFO, and in both cases the shipowner's choice is influenced heavily by the sulphur regulation and the trading pattern with respect to ECAs. The costs are substantial but distributed quite differently, with the LNG option carrying a massive upfront investment and savings on operational costs, and the use of distillate fuel being virtually all operating costs.

6.5 Feasibility in a regulatory context

The future scenarios of emissions from a given vessel are extraordinarily complicated over the next decade, with a number of possible interactions depending on the timing. As mentioned in the introductory part of the study, the future emissions of BC from shipping may be affected by the 2020 (or possibly 2025) reduction to 0.5% sulphur in fuel on a global scale and to 0.1% when travelling in ECAs, or by the corresponding reduction in sulphates (and particulate matter) arising from the use of exhaust gas cleaning systems. BC emissions will also be affected by the introduced Tier II and coming Tier III NO_x regulations.

6.5.1 Air emission regulation and the no action option: co-reduction of BC

The requirements of MARPOL Annex VI regarding Tier II NO_x reduction entered into force on 1 January 2011, and according to Dieselnets.com (Dieselnets 2010): *Tier II standards are expected to be met by combustion process optimization. The parameters examined by engine manufacturers include fuel injection timing, pressure, and rate (rate shaping), fuel nozzle flow area, exhaust valve timing, and cylinder compression volume.*

While some technical solutions to the Tier II requirement do not necessarily lead to reduced BC emissions, others do lead to notable BC effects, including WiFE, slide valves and de-rating combined with slow steaming.

Thus, given the renewal of the fleet, and in the perspective of a 2020 or 2030 horizon, a significant part of the global fleet may, through EEDI, NO_x requirements and sulphur reductions, already have co-reduced BC emissions inadvertently. Since the mechanisms of the aforementioned requirements to achieve their objectives are not defined, the precise reduction in BC resulting hereof cannot be assessed.

Therefore, the timing of a BC emission reduction regulation may have significant impact on the “value” of the regulatory action. If the IMO choose to implement BC regulation early, some abatement technologies acting on HFO (switching to low sulphur or using scrubbers) may be relevant, but if the action towards BC has a longer time frame, existing requirements under MARPOL will already have BC reduction potential through EEDI, SO_x and NO_x regulation.

A shipowner already facing investments regarding both sulphur and nitrogen oxides would possibly be positively inclined towards a BC abatement technology that was also addressing the other issues of air emissions, and, potentially, even fuel efficiency improvements.

The table below lists the six abatement technologies, of which some provide the BC reduction as part of a general reduction in fuel consumption.

Table 29 – *Tentative assessment of co-reduction of BC through other mechanisms for air pollution reduction*

	Sulphur and/or SO_x	NO_x	BC	Fuel savings
Slow steaming with de-rating	YES	YES	YES	YES
Water-in-Fuel Emulsion	YES	YES	YES	YES
HFO to distillate	YES	NO	YES	NO
LNG for propulsion	YES	YES	YES	YES
Diesel particulate filter	YES	NO	YES	NO
Scrubber – high sulphur fuel	YES	NO	YES	NO

6.5.2 Operational pattern relative to ECAs

Although it is not part of the current study to examine the effect of the operational pattern of a vessel, it is going to influence the shipowner's choice of the most beneficial BC abatement technology. For example, if all or most voyages take place in ECAs or on the high seas, as may be the case for ro-ro operations or large container vessels respectively, different abatement options might be considered. Operation in ECAs will favour certain technologies for which the alternative is low sulphur marine gas oil. For the High Seas vessels a technology compatible currently with HFO and later with 0.5% Sulphur Marine Diesel Oil may be preferred. Also, technologies that address requirements regarding both sulphur and nitrogen oxides will gain an advantage beyond 2020.

6.5.3 Assessment of abatement technologies regarding specific Arctic issues

The majority of vessels currently operating in the Arctic are vessels calling ports in the area rather than vessels transiting through the Northwest Passage or the Northern Sea Route. However, it is expected that the increase in traffic will be for vessels in transshipment such as tankers and bulkers, and for cruise ships and vessels operating for extended periods in the Arctic such as the OSV/AHTS and fishing vessels. Several of the abatement technologies may not be suited for vessels operating in the Arctic. This would include LNG, since the lack of bunkering infrastructure and relatively limited operational range of current designs of LNG-powered vessels does challenge the applicability.

The current study is directed at the ranking of various abatement technologies for the purpose of regulatory feasibility and, as such, not directed at assessing the cost for the global fleet composition – or an Arctic fleet given the possible trading patterns – and route viability in a future setting.

The global reduction in shipping's emissions of air pollutants will reduce the long-range transport of BC to the Arctic and will likewise reduce the locally generated BC originating from (international) shipping. The introduction of abatement technologies mentioned in this study may further reduce locally generated BC from international shipping by 50% to 90% depending on the actual technology.

6.6 Overview of technologies

In the table overleaf the technologies are presented with the key characteristics regarding their feasibility for existing vessels. The most feasible and cost-effective technologies may be found among slow steaming with de-rating, fuel switch to low sulphur or LNG. But WiFE is also a relatively simple technology with a reasonable cost effectiveness.

Several of the BC abatement technologies may be used in combination with one another for increased efficiency or some are already under consideration for other purposes (SO_x or NO_x reductions) and a BC abatement technology may be added. While the available body of data on BC does not allow any detailed analyses and it is not within the scope of the current study to evaluate the multiple combinations possible it may be noted that some technologies lend themselves to this option: for example, slow steaming operations (with engine retuning or de-rating) and diesel particulate filters will substantially reduce CO₂ and particle emissions. A small fuel penalty for DPF operation will mean fuel savings will be slightly reduced. Alternatively operation of engines on high quality fuels, in combination with DPFs, will produce significant SO_x and PM reductions, although both of these options come with a cost penalty. An alternative combination of technologies is a combination of

operational, fuel-based and after-treatment options such as slide valves, water in fuel emulsions and scrubbers (or DPF).

We caution that the efficiencies observed with one technology may not always be additive, and both antagonistic and synergistic effects may be observed when combining operational, fuel-based and after-treatment measures.

It is clear from the difficulties reported in monitoring BC in exhausts points towards certifying certain technologies, particularly if regulation is enacted within the coming decade. However, few technologies are thoroughly studied with respect to BC, although data on particles and hydrocarbons is used as proxies and thus the current basis for certification is not strong.

Table 30 – Factors impacting feasibility of technology

	BC reduction %	Cost effectiveness	Ties and co-reduction	Barriers to retrofit	Other barriers	Arctic barrier	Enforcement mechanism
SSDR	15	High	Not directly linked, but strong fuel saving motivation	Not possible for mechanically controlled engine	–	Variable loads under ice conditions	Not readily certifiable
WiFE	70	Medium	Will increase with NO _x regulation	Lack of emulsification in distillates	Few	No	Certifiable
HFO – Distillate	52	High	Driven by sulphur regulations	Few	Fuel availability	No	Certifiable
LNG	93.5	High	Driven by NO _x and sulphur regulations	Design challenges in vessel with no deck space	–	Bunkering infra-structure missing	Certifiable
DPF	85	Medium	No incentive from other regulation	Footprint restrictions	Immature technology	–	Certifiable
SWS	60	Medium	Driven by sulphur regulations	Footprint restrictions	–	May require heating	Certifiable
FWS	60	Low	Driven by sulphur regulations	Footprint restrictions	–	Heating of NaOH solution above 18°C to avoid crystallization	Certifiable

7

References

1. Bond, T. C., Streets, D. G., Yarber, K., Nelson, S. M., Woo, J.-H. and Klimont, Z., 2004, *A Technology-Based Global Inventory of Black Carbon and Organic Carbon Emissions from Combustion*, *Journal of Geophysical Research* 109(D14203): doi:10.1029/2003JD003697
2. Janssen, N. A. H., Gerlofs-Nijland, M. E. and Lanki, T., 2012, *Health Effects of Black Carbon*. http://www.euro.who.int/__data/assets/pdf_file/0004/162535/e96541.pdf
3. Smith, K. R., Jerrett, M., Anderson, H. R., Burnett, R. T., Stone, V., Derwent, R., Atkinson, R. W., Cohen, A., Shonkoff, S. B., Krewski, D., Pope, C. A., Thun, M. J. and Thurston, G., 2009, *Public Health Benefits of Strategies to Reduce Greenhouse-Gas Emissions: Health Implications of Short-Lived Greenhouse Pollutants*, *The Lancet* 374(9707): 2091-2103.
4. IPCC, 2007, *Climate Change 2007: The Physical Science Basis. Contribution of Working group 1 to the Fourth Assessment Report*. Report of the Intergovernmental Panel on Climate Change. S. Solomon, D. Qin, M. Manning et al. Cambridge, United Kingdom and New York, NY USA, Cambridge University Press
5. AMAP, 2011, *The Impact of Black Carbon on Arctic Climate*, AMAP Technical Report No. 4. Oslo, Norway, Arctic Monitoring and Assessment Programme (AMAP): 70pp. [http://amap.no/documents/index.cfm?action=getfile&dirsub=&filename=89439%5Fimpact of black carbon%5FFINAL.pdf&sort=default](http://amap.no/documents/index.cfm?action=getfile&dirsub=&filename=89439%5Fimpact%20of%20black%20carbon%5FFINAL.pdf&sort=default)
6. US-EPA, 2012, *Report to Congress on Black Carbon*. EPA-450/R-12-001. <http://www.epa.gov/blackcarbon/2012report/fullreport.pdf>
7. UNEP and WMO, 2012, *Integrated Assessment of Black Carbon and Tropospheric Ozone Summary for Decision Makers*, UNEP
8. IMO, 2012, *Definition and measurement of Black Carbon in international shipping*, BLG 16/15/4. Sub-Committee On Bulk Liquids And Gases. <http://docs.imo.org/Shared/Download.aspx?did=69893>
9. Lack, D. A., Lerner, B., Granier, C., Baynard, T., Lovejoy, E. R., Massoli, P., Ravishankara, A. R. and Williams, E., 2008, *Light Absorbing Carbon Emissions from Commercial Shipping*, *Geophys. Res. Lett.* 35(L13815): doi:10.1029/2008GL033906
10. Lack, D. A. and Corbett, J. J., 2012, *Black Carbon from Ships: A Review of the Effects of Ship Speed, Fuel Quality and Exhaust Gas Scrubbing*, *Atmos. Chem. Phys.* 12: 3985-4000 10.5194/acp-12-3985-2012
11. Corbett, J. J., Winebrake, J. J., Green, E. H., Kasibhatla, P., Eyring, V. and Lauer, A., 2007, *Mortality from Ship Emissions: A Global Assessment*, *Environ. Sci. Technol.* 41(24): DOI: 10.1021/es071686z
12. Eyring, V., et al. 2010, *Transport Impacts on Atmosphere and Climate: Shipping*. *Atmos. Environ.*, 44(37): p. 4735-4771
13. Lauer, A., et al. 2009, *Assessment of Near-Future Policy Instruments for Oceangoing Shipping: Impact on Atmospheric Aerosol Burdens and the Earth's Radiation Budget*. *Environ. Sci. Tech-nol.*, 43(15): p. 5592-5598
14. Fuglestedt, J., Berntsen, T., Eyring, V., Isaksen, I., Lee, D. S. and Sausen, R., 2009, *Shipping Emissions: From Cooling to Warming of Climate – and Reducing Impacts on Health*, *Environmental Science & Technology* 43(24): 9057-9062 10.1021/es901944r

15. NSIDC, 2007, *Arctic Sea Ice Shatters All Previous Record Lows. Diminished summer sea ice leads to opening of the fabled Northwest Passage 2007* [cited; Available from: http://nsidc.org/news/press/2007_seaiceminimum/20071001_pressrelease.html and <http://nsidc.org/arcticseaicenews/>]
16. ACIA, 2004, *Impacts of a Warming Arctic: Arctic Climate Impact Assessment*, Cambridge University Press
17. AMSA, 2009, *Arctic Marine Shipping Assessment 2009 Report*, Arctic Council.
http://www.arctic.gov/publications/AMSA_2009_Report_2nd_print.pdf
18. ECON, 2007, *Arctic Shipping 2030: From Russia with Oil, Stormy Passage, or Arctic Great Game?*, Oslo. 2007-070: 1-25.
http://www.econ.no/stream_file.asp?iEntityId=3244
19. Laulajainen, R., 2009, *The Arctic Sea Route*, Int. J. Shipping and Transport Logistics 1(1): doi: 10.1504/IJSTL.2009.021976
20. Serreze, M. C., Holland, M. M. and Stroeve, J., 2007, *Perspectives on the Arctic's Shrinking Sea-Ice Cover*, Science 315(5818): 1533-1536 10.1126/science.1139426
21. Shindell, D. and Faluvegi, G., 2009, *Climate response to regional radiative forcing during the twentieth century*, Nature Geosci 2(4): 294-300
22. Law, K. and Stohl, A., 2007, *Arctic Air Pollution: Origins and Impacts*, Science 315(1537): DOI: 10.1126/science.1137695
23. McConnell, J. R., Edwards, R., Kok, G. L., Flanner, M. G., Zender, C. S., Saltzman, E. S., Banta, J. R., Pasteris, D. R., Carter, M. M. and Kahl, J. D. W., 2007, *20th-Century Industrial Black Carbon Emissions Altered Arctic Climate Forcing*, Science 317(5843): 1381-1384 10.1126/science.1144856
24. Quinn, P. K., Bates, T. S., Baum, E., Doubleday, N., Fiore, A. M., Flanner, M., Fridlind, A., Garrett, T. J., Koch, D., Menon, S., Shindell, D., Stohl, A. and Warren, S. G., 2008, *Short-lived pollutants in the Arctic: their climate impact and possible mitigation strategies*, Atmos. Chem. Phys. 8(6): 1723-1735
25. Quinn, P. K., Shaw, G., Andrews, E., Dutton, E. G., Ruoho-Airola, T. and Gong, S. L., 2007, *Arctic haze: current trends and knowledge gaps*, Tellus 59B: 99-144.
26. Stohl, A., Andrews, E., Burkhardt, J. F., Forster, C., Herber, A., Hoch, S. W., Kowal, D., Lunder, C., Mefford, T., Ogren, J. A., Sharma, S., Spichtinger, N., Stebel, K., Stone, R., Strom, J., Tørseth, K., Wehrli, C. and Yttri, K. E., 2006, *Pan-Arctic enhancements of light absorbing aerosol concentrations due to North American boreal forest fires during summer 2004*, Journal of Geophysical Research 111(D22214): doi:10.1029/2006JD007216
27. Flanner, M. G., Zender, C. S., Randerson, J. T. and Rasch, P. J., 2007, *Present-day climate forcing and response from black carbon in snow*, Journal of Geophysical Research 112(D11202): doi:10.1029/2006JD008003
28. Corbett, J. J., Lack, D. A., Winebrake, J. J., Harder, S., Silberman, J. A. and Gold, M., 2010, *Arctic shipping emissions inventories and future scenarios*, Atmos. Chem. Phys. 10(19): 9689-9704 10.5194/acp-10-9689-2010
29. Peters, G. P., Nilssen, T. B., Lindholt, L., Eide, M. S., Glomsrød, S., Eide, L. I. and Fuglestad, J. S., 2011, *Future emissions from shipping and petroleum activities in the Arctic*, Atmos. Chem. Phys. 11(11): 5305-5320 10.5194/acp-11-5305-2011
30. Bailey, D., Holland, M., Lack, D., Lamarque, J. F., Flanner, M. and Corbett, J. J., 2011, *Potential impacts of 21st century Arctic shipping. World Climate Research Program*. Denver, CO.
http://www.star.nesdis.noaa.gov/star/documents/meetings/lce2011/posters/NIC_Bailey.pdf.
31. Dalsøren, S. B., Samset, B. H., Myhre, G., Corbett, J. J., Minjares, R., Lack, D. and Fuglestad, J. S., 2012, *Environmental impacts of shipping in 2030 with a particular focus on the Arctic region*, Atmos. Chem. Phys. Discuss. 12(10): 26647-26684 10.5194/acpd-12-26647-2012
32. IMO, 2010, *Emissions inventory and analysis of impacts of short-lived climate forcing aerosols from international shipping activity in the Arctic*, BLG 15/INF.5.
<http://docs.imo.org/Shared/Download.aspx?did=64259>

33. IMO, 1997, *Technical Code on Control of Emission of Nitrogen Oxides from Marine Diesel Engines (NO_x Technical Code)*, IMO. 13.
<http://www.imo.org/ourwork/environment/pollutionprevention/airpollution/pages/nitrogen-oxides-%28NO_x%29-%E2%80%93regulation-13.aspx>
34. IMO, 2010, *Air Pollution from Ships Cut with Entry Into Force of MARPOL Amendments*.
http://www.imo.org/newsroom/mainframe.asp?topic_id=1859&doc_id=13309.
35. IMO, 2009, *Second IMO Greenhouse Study 2009*.
http://www.imo.org/blast/blastDataHelper.asp?data_id=27795&filename=GHGStudyFINAL.pdf.
36. IMO, 2011, *Amendments to the Annex of the Protocol of 1997 to Amend the International Convention for the Prevention of Pollution from Ships, 1973, as Modified by the Protocol of 1978 Relating Thereto (Inclusion of regulations on energy efficiency for ships in MARPOL Annex VI)*. Resolution MEPC.203(62). International-Maritime-Organization.
[http://www.imo.org/MediaCentre/HotTopics/GHG/Documents/eedi amendments RESOLUTION MEPC203 62.pdf](http://www.imo.org/MediaCentre/HotTopics/GHG/Documents/eedi%20amendments%20RESOLUTION%20MEPC203%2062.pdf)
37. IMO, 2011, *Report of the Marine Environment Protection Committee on its Sixty-Second Session*, MEPC 62/24.
<http://docs.imo.org/Shared/Download.aspx?did=68320>
38. IMO, 2006, *Report to the Maritime Safety Committee and the Marine Environment Protection Committee*, BLG 10/19. Sub-Committee On Bulk Liquids And Gases.
<http://docs.imo.org/Shared/Download.aspx?did=37738>
39. IMO, 2007, *Report to the Maritime Safety Committee and the Marine Environment Protection Committee*, BLG 11/16. Sub-Committee On Bulk Liquids And Gases.
<http://docs.imo.org/Shared/Download.aspx?did=43029>
40. IMO, 2008, *Report to the Maritime Safety Committee and the Marine Environment Protection Committee*, BLG 12/17. Sub-Committee On Bulk Liquids And Gases.
<http://docs.imo.org/Shared/Download.aspx?did=47528>
41. IMO, 2007, *Proposal for the measurement method for particulate matter emitted from marine diesel engines*, BLG 12/6/14. Review Of Marpol Annex Vi And The NO_x Technical Code.
<http://docs.imo.org/Shared/Download.aspx?did=46015>
42. IMO, 2009, *Report of the Marine Environment Protection Committee on its Fifty-Ninth Session*, MEPC 59/24.
<http://docs.imo.org/Shared/Download.aspx?did=56200>
43. IMO, 2010, *Report of the Marine Environment Protection Committee on its Sixty-First Session*, MEPC 61/24. <http://docs.imo.org/Shared/Download.aspx?did=63388>
44. IMO, 2010, *Reduction of emissions of black carbon from shipping in the Arctic. Prevention of Air Pollution from Ships*.
<http://docs.imo.org/Shared/Download.aspx?did=58243>
45. IMO, 2011, *Report to the Maritime Safety Committee and the Marine Environment Protection Committee*, BLG 15/19. Sub-Committee On Bulk Liquids And Gases.
<http://docs.imo.org/Shared/Download.aspx?did=65804>
46. IMO, 2010, *Report to the Executive Body for the Convention on Long-range Transboundary Air Pollution by the Co-Chairs of the Ad Hoc Expert Group on Black Carbon*, BLG 15/INF.8.
<http://docs.imo.org/Shared/Download.aspx?did=64474>
47. IMO, 2012, *Impact of fuel quality regulation and speed reductions on shipping emissions: Implications for climate and air quality*, BLG 16/Inf.5. Sub-Committee On Bulk Liquids And Gases.
<http://docs.imo.org/Shared/Download.aspx?did=69842>
48. IMO, 2012, *Emissions of Black Carbon from international shipping – IMO definition*, BLG 16/15/1. Sub-Committee On Bulk Liquids And Gases.
<http://docs.imo.org/Shared/Download.aspx?did=69905>

49. IMO, 2012, *Impact on the Arctic of Emissions of Black Carbon from International Shipping*, BLG 16/15/2. Sub-Committee On Bulk Liquids And Gases.
<http://docs.imo.org/Shared/Download.aspx?did=69878>
50. IMO, 2012, *Consideration of Black Carbon Emissions*, BLG 16/15/3. Sub-Committee On Bulk Liquids And Gases.
<http://docs.imo.org/Shared/Download.aspx?did=69879>
51. IMO, 2012, *Reduction of emissions of Black Carbon from shipping in the Arctic*, BLG 16/15/5. Sub-Committee On Bulk Liquids And Gases.
<http://docs.imo.org/Shared/Download.aspx?did=69894>
52. CARB, 2004, *The California Diesel Fuel Regulations*.
<http://www.arb.ca.gov/regs/regs.htm>
53. EU, 1993, *Directive 93/12/EEC of 23 March 1993 relating to the sulphur content of certain liquid fuels*, Official Journal of the European Communities L074: 0081-0082
54. EU, 2003, *Directive 2003/17/EC of the European Parliament and of the Council of 3 March 2003 amending Directive 98/70/EC relating to the quality of petrol and diesel fuels*, Official Journal of the European Communities L076: 0010-0019
55. Lack, D. A., Langridge, J. M., Bahreini, R., Brock, C. A., Middlebrook, A. M. and Schwarz, J. P., 2012, *Brown Carbon and Internal Mixing in Biomass Burning Particles*, Proceedings of the National Academy of Sciences, In Preparation
56. Burtscher, H., 2005, *Physical characterization of particulate emissions from diesel engines: a review*, Journal of Aerosol Science 36(7): 896-932 10.1016/j.jaerosci.2004.12.001
57. US-EPA, 2005, *Emissions Modeling Clearinghouse Speciation, Titles and Documentation for PM Profiles*.
http://www.epa.gov/ttn/chief/emch/speciation/pm25_prof_titles_revised.xls
58. Schwarz, J. P., Gao, R. S., Spackman, J. R., Watts, L. A., Thomson, D. S., Fahey, D. W., Ryerson, T. B., Peischl, J., Holloway, J. S., Trainer, M., Frost, G. J., Baynard, T., Lack, D. A., de Gouw, J. A., Warneke, C. and Del Negro, L. A., 2008, *Measurement of the Mixing State, Mass, and Optical Size of Individual Black Carbon Particles in Urban and Biomass Burning Emissions*, Geophys. Res. Lett. 35 10.1029/2008gl033968
59. Kondo, Y., Matsui, H., Moteki, N., Sahu, L., Takegawa, N., Kajino, M., Zhao, Y., Cubison, M. J., Jimenez, J. L., Vay, S., Diskin, G. S., Anderson, B., Wisthaler, A., Mikoviny, T., Fuelberg, H. E., Blake, D. R., Huey, G., Weinheimer, A. J., Knapp, D. J. and Brune, W. H., 2011, *Emissions of black carbon, organic, and inorganic aerosols from biomass burning in North America and Asia in 2008*, J. Geophys. Res. 116(D8): D08204 10.1029/2010jd015152
60. Sedlacek, A. J., III, Lewis, E. R., Kleinman, L., Xu, J. and Zhang, Q., 2012, *Determination of and evidence for non-core-shell structure of particles containing black carbon using the Single-Particle Soot Photometer (SP2)*, Geophys. Res. Lett. 39(6): L06802 10.1029/2012gl050905
61. Seinfeld, J. H. and Pandis, S. N., 1998, *Atmospheric Chemistry and Physics: From air pollution to climate change*. New York, John Wiley and Sons, Inc.
62. Fathom, 2011, *Ship Efficiency: The Guide A comprehensive guide to ship eco-efficiency technologies and measures*. Berkshire, UK
63. IMO, 2011, *Energy Efficiency Design Index – Technical and Operational Measures*.
<http://www.imo.org/OurWork/Environment/PollutionPrevention/AirPollution/Pages/Technical-and-Operational-Measures.aspx>
64. Ritchie, A., Jonge, E., Hugi, C. and Cooper, D., 2005, *European Commission Directorate General Environment, Service Contract on Ship Emissions: Assignment, Abatement and Market-based Instruments: Task 2b – NO_x Abatement*, Entec UK Limited: Northwich, Cheshire, UK. p. 60
65. Corbett, J. J., Winebrake, J. J. and Green, E. H., 2010, *An Assessment of Technologies for Reducing Regional Short-Lived Climate Forcers Emitted by Ships with Implications for Arctic Shipping*, Carbon Management 1(2): 207-225 10.4155/cmt.10.27

66. Fournier, A., 2006, *Controlling Air Emissions from Marine Vessels: Problems and Opportunities*, Donald Bren School of Environmental Science and Management. Santa Barbara, California, USA, University of California Santa Barbara
67. MAN, 2002, *Considerable Emission Reductions and Improved Operation with Slide Fuel Valves*. News from MAN B&W Diesel.
[http://mandieselturbo.com/files/news/files737/Slide Fuel Valves 190802.pdf](http://mandieselturbo.com/files/news/files737/Slide_Fuel_Valves_190802.pdf)
68. MAN, 2012, *Slow Steaming Practices in the Global Shipping Industry: Results of a survey conducted by MAN PrimeServ in late 2011 among representatives of the global container, bulk and tanker shipping industry*. 2/2012,
<http://www.manslowsteaming.com>
69. Henningsen, S., 2004, *MV Sine Maersk Emission Measurements & Retrofit Control Technology Discussion*, The MARAD Shipboard Energy Technologies Workshop. Sacramento, CA, USA
70. CIMAC, 2012, *Background Information on Black Carbon Emissions from Large Marine and Stationary Diesel Engines – Definition, Measurement Methods, Emission Factors and Abatement Technologies*.
[http://www.cimac.com/cimac_cms/uploads/explorer/Working groups/black_carbon.pdf](http://www.cimac.com/cimac_cms/uploads/explorer/Working_groups/black_carbon.pdf)
71. MAN, 2004, *Low Container Ship Speed Facilitated by Versatile ME/ME-C Engines*.
<http://www.mandieselturbo.de/files/news/files8410/5510-0038-04.pdf>
72. Wettstein, R. and Brown, D., 2008, *Derating: A Solution for High Fuel Savings and Lower Emissions*.
<http://www.wartsila.com/file/Wartsila/1278512639967a1267106724867-Wartsila-SP-Tech-2008-Derating.pdf>
73. MAN, 2004, *MAN Diesel Common Rail*. 6L32/40CR.
[http://www.mandiesel.com.cn/files/news/files15981/Commonrail Brochure.pdf](http://www.mandiesel.com.cn/files/news/files15981/Commonrail_Brochure.pdf)
74. Harvald, S., 1977, *Prediction of Power of Ships*, Lyngby, Denmark: Department of Ocean Engineering, Technical University of Denmark
75. Faber, J., Nelissen, D., Hon, G., Wang, H. and Tsimplis, M., 2012, *Regulated Slow Steaming in Maritime Transport: An Assessment of Options, Costs and Benefits*.
[http://www.transportenvironment.org/sites/default/files/media/Slow steaming CE Delft final.pdf](http://www.transportenvironment.org/sites/default/files/media/Slow_steaming_CE_Delft_final.pdf)
76. Maersk, 2010, *Slow Steaming Here to Stay*.
<http://www.maersk.com/AboutMaersk/News/Pages/20100901-145240.aspx>.
77. PWC, 2011, *A Game Changer for the Shipping Industry? An analysis of the future impact of carbon regulations on environment and industry*.
<http://www.scribd.com/doc/68027866/Shipping-GHG-PwC-Final>
78. Jorgensen, R., 2010, *Slow Steaming: The Full Story*.
[http://www.maersk.com/Innovation/WorkingWithInnovation/Documents/Slow Steaming – the full story.pdf](http://www.maersk.com/Innovation/WorkingWithInnovation/Documents/Slow_Steaming_-_the_full_story.pdf)
79. IMO, 2007, *Estimation method of particulate matter emitted from marine engines*, BLG 11/5/18. REVIEW OF MARPOL ANNEX VI AND THE NO_x TECHNICAL CODE.
<http://docs.imo.org/Shared/Download.aspx?did=41566>
80. Miller, J. W., Khan, M. Y., Welch, W. A. and Gutierrez, J., 2010, *On-Board C3 Marine Engine Measurement of Emission Reductions from Fuel Switching at the Port of Houston and a Mexican Port*, University of California, Riverside
81. Issa, M., Petit, C., Brillard, A. and Brillhac, J.-F. O., 2008, *Oxidation of carbon by CeO₂: Effect of the contact between carbon and catalyst particles*, Fuel 87(6): 740-750 10.1016/j.fuel.2007.05.053
82. Maricq, M. M., 2007, *Chemical Characterization of Particulate Emissions from Diesel Engines: A Review*, J. Aero. Sci 38(11): 1079-1118 10.1016/j.jaerosci.2007.08.001
83. MECA, 2007, *Emission Control Technologies for Diesel-Powered Vehicles*.
[http://www.meca.org/galleries/default-file/MECA Diesel White Paper 12-07-07 final.pdf](http://www.meca.org/galleries/default-file/MECA_Diesel_White_Paper_12-07-07_final.pdf)

84. Ristimäki, J., Hellem, G. and Lappi, M., 2010, *Chemical and Physical Characterization of Exhaust Particulate Matter from a Marine Medium Speed Diesel Engine*, CIMAC Congress. Bergen, International Council on Combustion Engines.
http://www.researchgate.net/publication/41205230_Chemical_and_physical_characterization_of_exhaust_particulate_matter_from_a_marine_medium_speed_diesel_engine
85. Cotel, E. W., 2012 (personal communication; available upon request from E.W. Cotel or Lithauz). NoNO_x Ltd. Emulsion Combustion Technology, NoNO_x Ltd
86. Einemo, U., 2012, *Emulsion fuel system promises fuel savings, emission reductions*. SustainableShipping.com
http://www.sustainableshipping.com/news/i109570/Emulsion_fuel_system_promises_fuel_savings_emission_reductions
87. Inerco, 2012 (personal communication; available upon request from Lithauz). Caracterización de Emisiones Durante la Inyección de Aditivos en Una Caldera de Fuel-Oil de la Ladrillería "El Prado en Velez-Málaga"
88. American-Bureau-of-Shipping, 2001, *Notes on Heavy Fuel Oil*.
http://www.eagle.org/eagleExternalPortalWEB/ShowProperty/BEA_Repository/Rules&Guides/Current/31_HeavyFuelOil/Pub31_HeavyFuelOil.pdf
89. Lack, D. A., Cappa, C. D., Langridge, J., Bahreini, R., Buffaloe, G., Brock, C., Cerully, K., Coffman, D., Hayden, K., Holloway, J., Lerner, B., Massoli, P., Li, S.-M., McLaren, R., Middlebrook, A. M., Moore, R., Nenes, A., Nuaaman, I., Onasch, T. B., Peischl, J., Perring, A., Quinn, P. K., Ryerson, T., Schwartz, J. P., Spackman, R., Wofsy, S. C., Worsnop, D., Xiang, B. and Williams, E., 2011, *Impact of Fuel Quality Regulation and Speed Reductions on Shipping Emissions: Implications for Climate and Air Quality*, *Environmental Science & Technology* 45(20): 9052-9060 10.1021/es2013424
90. Petzold, A., Lauer, P., Fritsche, U., Hasselbach, J., Lichtenstern, M., Schlager, H. and Fleischer, F., 2011, *Operation of Marine Diesel Engines on Biogenic Fuels: Modification of Emissions and Resulting Climate Effects*, *Environ. Sci. Technol.* 45(24): 10394 – 10400 10.1021/es2021439
91. Winebrake, J. J., Corbett, J. J. and Meyer, P. E., 2007, *Energy Use and Emissions from Marine Vessels: A Total Fuel Life Cycle Approach*, *J. Air & Waste Manage. Assoc.* 57: 102-110
92. Xue, J., Grift, T. E. and Hansen, A. C., 2011, *Effect of biodiesel on engine performances and emissions*, *Renewable and Sustainable Energy Reviews* 15(2): 1098-1116 10.1016/j.rser.2010.11.016
93. US-EPA, 2002, *A Comprehensive Analysis of Biodiesel Impacts on Exhaust Emissions – Draft Technical Report*. EPA420-P-02-001.
<http://www.epa.gov/oms/models/analysis/biodsl/p02001.pdf>
94. Jayaram, V., Agrawal, H., Welch, W. A., Miller, J. W. and Cocker, D. R., 2011, *Real-Time Gaseous, PM and Ultrafine Particle Emissions from a Modern Marine Engine Operating on Biodiesel*, *Environmental Science & Technology* 45(6): 2286-2292 10.1021/es1026954
95. Lloyds, 2010, *Maersk and Lloyd's Register team up for marine engine bio-fuel tests*.
http://www.lr.org/news_and_events/press-releases/181528-maersk-and-lloyds-register-team-up-for-marine-engine-biofuel-tests.aspx
96. CAIP, 2004, *Compressed Natural Gas versus Diesel, Results of Vehicle Testing at Mirs Lab*.
pdf.usaid.gov/pdf_docs/PNACX796.pdf
97. Coroller, P., Plassat, G. and Seguelong, T., 2003, *Comparative Study on Exhaust Emissions from Diesel- and CNG-Powered Urban Buses*. Diesel Engine Emissions Reduction (DEER) Conference, Rhode Island, USA.
http://www.eere.energy.gov/vehiclesandfuels/pdfs/deer_2003/session5/deer_2003_dunn.pdf
98. Hesterberg, T. W., Lapin, C. A. and Bunn, W. B., 2008, *A Comparison of Emissions from Vehicles Fueled with Diesel or Compressed Natural Gas*, *Environmental Science & Technology* 42(17): 6437-6445 10.1021/es071718i
99. NORDEN, 2012, *SPIRETH – Alcohol (Spirits) and Ethers as marine fuel*.
<http://www.nordicenergy.org/project/alcohol-spirits-and-ethers-as-marine-fuel/>

100. Duwig, C., Gabrielsson, P. and Højlund-Nielsen, P. E., 2011, *SPIRETH: Methanol fuelled Diesel engine using the OBATE technology. Energy Efficient Shipping Through Ultra-Slow Steaming.*
<http://www.marindagen.se/wp-content/uploads/2010/11/P.E.-H%C3%B8jlund-Nielsen.pdf>
101. Wartsilla, 2010, *Fuels of the future – What will come next after HFO?* CIMAC Congress 10.
http://www.cimac.com/cimac_cms/uploads/explorer/Congress_2010/panel_presentations_thursday/CIMAC_Panel_Thursday_all.pdf
102. Ramne, B., 2011, *EFF Ship, Efficient Shipping with Low Emissions.*
http://www.effship.com/PublicPresentations/EffShip_Transportforum_12-13_januari_2011-Final1.ppt
103. MAN, 2011, *New Liquid ME-GI Engine Signals Expansion of MAN B&W Gas Portfolio.*
http://www.mandieselturbo.com/files/news/files/15559/Master_PR_LPG_ME-LGI_engine.pdf
104. BioDME, 2012, *Production of DME from biomass and utilisation of fuel for transport and industrial use.*
<http://www.biodme.eu/about-dme>
105. Maersk, 2012 (personal communication; contact Maersk for further use and permissions). Bio fuel trial on seagoing vessel. Netherlands, Maersk Ship Management
106. Ariana, I. M., Nishida, O., Fujita, H., Harano, W. and Fujio, M., 2006, *Removal of Marine Diesel Particulate Matter by Electrostatic Precipitator*, ICESP X. Australia. Paper 4A2.
http://www.isesp.org/ICESP_X_PAPERS/PDFS/Paper_4A2.pdf
107. Farnoud, A., 2008, *Electrostatic removal of diesel particulate matter*, Southern Methodist University. PhD.
<http://gradworks.umi.com/33/03/3303839.html>
108. Hayashi, H., Kimura, M., Kawahara, K., Takasaki, Y., Takashima, K. and Mizuno, A., 2009, *Collection of diesel exhaust particle using electrostatic charging prior to mechanical filtration*, Electrostatics Joint Conference. Boston, MA, USA.
http://www.electrostaticanswers.com/2009ESJC/Session04/2009_Hayashi_Collection_of_diesel_exhaust_particle_using_electrostatic_charging.pdf
109. Kawakami, H., Zukeran, A., Yasumoto, K., Inui, T., Ehara, Y. and Yamamoto, T., 2011, *Diesel PM Collection for Marine Emissions Using Double Cylinder Type Electrostatic Precipitator*, International Journal of Plasma Environmental Science & Technology 5(2): 174-178
110. Yamamoto, T., Mimura, T., Otsuka, N., Ito, Y., Ehara, Y. and Zukeran, A., 2010, *Diesel PM Collection for Marine and Automobile Emissions Using EHD Electrostatic Precipitators*, Industry Applications, IEEE Transactions on 46(4): 1606-1612 10.1109/tia.2010.2049970
111. Lin, C.-Y., 2002, *Reduction of particulate matter and gaseous emission from marine diesel engines using a catalyzed particulate filter*, Ocean Engineering 29(11): 1327-1341 10.1016/s0029-8018(01)00086-5
112. EmiNO_x, 2011, *CRT System Operation and Maintenance Manual.*
http://www.emiNOx.com/assets/documents-and-downloads/English_CRT_manual_LR.pdf
113. Lowell, D., 2003, *Comparison of Clean Diesel Buses to CNG Buses.* Diesel Engine Emissions Reduction (DEER) Conference. Rhode Island, USA, US Department of Energy.
http://www1.eere.energy.gov/vehiclesandfuels/pdfs/deer_2003/session5/deer_2003_lowell.pdf
114. US-EPA, 2010, *Diesel Particulate Filter General Information.* United States Environmental Protection Agency Technical Bulletin.
<http://www.epa.gov/cleandiesel/documents/420f10029.pdf>
115. Liu, Z. G., Berg, D. R. and Schauer, J. J., 2009, *Detailed Effects of a Diesel Particulate Filter on the Reduction of Chemical Species Emissions*, SAE International Journal of Fuels and Lubricants 1(1): 184-191
116. Huss, 2009, *Diesel Particulate Filter with Active Diesel Burner Technology.*
http://www.hussgroup.com/group/en/shared_content/download_files/02-EN_MK.pdf
117. MOL, 2012, *MOL Introduces Technology to Eliminate Particulate Emissions from Vessels – Announces demonstration test of Diesel Particulate Filter.*
http://www.mol.co.jp/pr-e/2012/e-pr_1209.html

118. US-EPA, 2010, *Diesel Oxidation Catalyst General Information*. United States Environmental Protection Agency Technical Bulletin.
<http://www.epa.gov/cleandiesel/documents/420f10031.pdf>
119. EmiNO_x, 2009, *EmiNO_x SCR System – NO_x Reducing Technology*.
[http://www.emiNOx.com/assets/documents-and-downloads/\(5\) English SCR Leaflet Sep 09 LR_1.pdf](http://www.emiNOx.com/assets/documents-and-downloads/(5) English SCR Leaflet Sep 09 LR_1.pdf)
120. Nuszowski, J., Clark, N. N., Spencer, T. K., Carder, D. K., Gautam, M., Balon, T. H. and Moynihan, P. J., 2009, *Atmospheric Emissions from a Passenger Ferry with Selective Catalytic Reduction*, *Journal of the Air & Waste Management Association* 59(1): 18-30 10.3155/1047-3289.59.1.18
121. MAN, 2012, *Pers. Comm. with Michael Finch Pedersen, MAN Diesel & Turbo*. Sept.
122. Lloyds, 2012, *Understanding exhaust gas treatment systems: Guidance for shipowners and operators*.
[http://www.lr.org/Images/Understanding exhaust gas treatment systems June 2012_tcm155-240772.pdf](http://www.lr.org/Images/Understanding%20exhaust%20gas%20treatment%20systems%20June%202012_tcm155-240772.pdf)
123. Couple-Systems, 2010, *Dry Exhaust Gas Cleaning System*.
<http://www.egcsa.com/pdfs/Couple-Systems-EGCS-SMM-Workshop-2010.pdf>
124. Hombravella, A., Kihcaslan, A., Perales, J. and Rub, C., 2011, *Study of Exhaust Gas Cleaning Systems for Vessels to Fulfill IMO III in 2016*.
[http://upcommons.upc.edu/pfc/bitstream/2099.1/13745/1/CAT FINAL REPORT.pdf](http://upcommons.upc.edu/pfc/bitstream/2099.1/13745/1/CAT_FINAL_REPORT.pdf)
125. International-Standards-Organization, 1996, *Reciprocating internal combustion engines – Exhaust emission measurement – Part 1: Test-bed measurement of gaseous particulate exhaust emissions*. ISO 8178-1
126. Ritchie, A., Jonge, E., Hugli, C. and Cooper, D., 2005, *European Commission Directorate General Environment, Service Contract on Ship Emissions: Assignment, Abatement, and Market-based Instruments*. Task 2b – NO_x Abatement.
ec.europa.eu/environment/air/pdf/task2_NOx.pdf
127. CARB, 2002, *Oceangoing Marine Vessel Emission Control Technology Matrix*.
<http://www.arb.ca.gov/ports/marinevess/documents/matrix.pdf>
128. Cotel, E.W., 2012, *Emission Control Technology for Engines and Boilers Pays for Itself in Fuel Savings*.
<http://www.noNOxLtd.com/WhitePaper.html>
129. Einemo, U., 2012, *Emulsifier inventor promises huge emission reductions*. SustainableShipping.com
<http://www.sustainableshipping.com/news/2012/5/113958?tag=45-81976-10013373-0-SS>
130. GSOTF, 2012, *Green Ships of the Future*, Vessel Emissions Study
131. MAN, 2006, *Faster Freight Cleaner Air*
132. MAN, *Emulsion Cost Overview*
133. Diesel, M., *Operation on Low-Sulphur Fuels*
134. Mitsui, O.S.K.L., 2010, *MOL Develops Marine Use Diesel Particulate Filter*
135. den Boer, E., 2011, *Emissions from the Legacy Fleet*
136. Longva, T., 2011, *Emission reduction potential in shipping*. EECF – WG ships meeting 3, DNV
137. Andreasen, A. (MAN Diesel) & Nygaard K.B. (Danisco) (2011), *Danish Ministry of the Environment (Water-in-fuel emulsion as marine engine fuel for reduced NO_x and particulate emissions – Environmental Project No. 1380 2011)*
138. Jayaram, V., Miller, J.W., Nigam, A., Welch, W.A., Cocker, D.R., 2009, *Effect of Selective Catalytic Reduction Unit on Emissions from and Auxilliary Engine on an Ocean-Going Vessel*. Final Report to California Air Resources Board.
<http://www.arb.ca.gov/ports/marinevess/documents/emissionstest/post%20panamax%20AUX%20SCR%20final.pdf>

Appendices

Appendix A

Cost Overview**(table numbers refer to tables in Erria report set out in appendix E)***Table derived from table 34, CAPEX (USD) from Erria report*

Cost index	EEDI		De-rating		Emulsion		LNG		HFO-distillate/day		DPF		Scrubber	
1. Aframax	0.73		0.73		0.51		0.90		0.51		0.72		0.90	
2. Container	4.40	5.30	4.40	5.30	3.67	5.29	5.65	6.05	3.66	5.24	4.37	5.31	4.97	5.31
3. Bulk carrier	0.93	0.94	0.93	0.94	0.91	0.93	1.05	1.07	0.90	0.90	0.93	0.94	0.93	0.94
4. Gas	1.41	1.37	1.41	1.37	1.43	1.37	1.56	1.57	1.41	1.33	1.41	1.38	1.39	1.38
5. Passenger	4.22	3.41	4.22	4.68	3.85	4.68	5.11	5.34	3.83	4.62	4.21	4.68	4.51	4.69
6. OSV/AHTS	1.20	1.00	1.20	1.00	1.37	1.00	1.20	1.14	1.37	1.00	1.21	1.00	1.08	1.00
7. Tug	0.41	0.38	0.41	0.38	0.44	0.39	0.44	0.43	0.44	0.38	0.41	0.38	0.39	0.38

Table 33 from Erria report

Off-hire rates	EEDI	De-rating	WIFE	LNG	HFO-distillate	DPF	Scrubber	Off hire rates
Aframax	30	30	20	40	10	20	30	USD 20,000
Container	30	30	20	40	10	20	30	USD 40,000
Bulk carrier	30	30	20	40	10	20	30	USD 18,000
Gas	30	30	20	40	10	20	30	USD 30,000
Passenger	30	30	20	40	10	20	30	USD 60,000
OSV/AHTS	30	30	20	40	10	20	30	USD 35,000
Tug	30	30	20	40	10	20	30	USD 10,000

Table 30 from Erria report

Cost per kW excl. off-hire cost	Aframax	Container	Bulk carrier	Gas	Passenger	OSV/AHTS	Tug
EEDI	USD 100	USD 100	USD 100	USD 100	USD 100	USD 100	USD 100
Slow steaming: with de-rating	USD 100	USD 100	USD 100	USD 100	USD 100	USD 100	USD 100
WIFE	USD 26	USD 26	USD 26	USD 26	USD 26	USD 26	USD 26
LNG	USD 455	USD 518	USD 518	USD 518	USD 518	USD 518	USD 518
DPF	USD 63	USD 63	USD 63	USD 63	USD 63	USD 63	USD 63
HFO-distillate	USD 13	USD 13	USD 13	USD 13	USD 13	USD 13	USD 13
Scrubber	USD 330	USD 330	USD 330	USD 330	USD 330	USD 330	USD 330

Table 27 from Erria report

SFOC (Specific Fuel Oil Consumption)			
	HFO	LS MGO	LNG
2-Stroke	0.182	0.171	0.155
2-Stroke (de-rated)	0.171	0.161	0.145
4-Stroke	0.209	0.196	0.178
4-Stroke (de-rated)	0.196	0.185	0.167

Table 9 from Erria report

Fuel price – world wide	HFO 380 1–3.5%S	MGO 0.1%S	LNG
Singapore	USD 676.00	USD 995.00	USD 412.00
Rotterdam	USD 653.50	USD 975.00	USD 389.00
Houston	USD 671.50	USD 1,040.00	
Fujairah	USD 681.50	USD 1,026.00	
Los Angeles	USD 686.50	USD 1,097.00	
Durban		USD 1,131.50	
Tokyo	USD 718.50	USD 1,008.00	
New York	USD 663.50		
Average:	USD 678.71	USD 1,038.93	USD 400.50

Appendix B

Calculations according to Corbett

Tables 31 to 35 provide estimates of energy use, total cost of technology, pollution reduction and cost effectiveness of BC reduction for the different abatement technologies: slow steaming, water-in-fuel emulsification (WiFE), switch to liquid natural gas (LNG), diesel particulate filters (DPF), seawater scrubbing (SWS) and freshwater scrubbing (FWS). All estimates are made for an engine power of 10,000 kW, total annual operating hours of 6,240, use of marine diesel oil (MDO) and an average engine load fraction of 0.72. The base scenario uses a discount rate of 7% and MDO cost of 1011.8 USD/mt (table 31). A sensitivity analysis assessing the impact on cost of changing discount rates and MDO costs has been made (tables 32 to 35). The lowest and the highest MDO price since March 2009 have been used.

Table 31 – Best estimates for the different technologies using MDO fuel cost of 1011.8 USD/mt and a discount rate of 7%

	Energy use (kWh/year)	Total cost (USD/year)	Pollution reduction (g/year)	Cost effectiveness (USD/g BC)
Slow steaming	3.12E + 07	-2.52E + 06	9.61E + 05	-2.62
WiFE	4.49E + 07	1.04E + 05	1.57E + 06	0.07
LNG	4.49E + 07	-5.09E + 06	2.94E + 06	-1.73
DPF	4.49E + 07	5.58E + 05	2.67E + 06	0.21
SWS	4.49E + 07	3.92E + 05	1.26E + 06	0.31
FWS	4.49E + 07	1.12E + 07	1.26E + 06	8.92

Table 32 – Estimates for the different technologies using MDO fuel cost of 1011.8 USD/mt and a discount rate of 10%

	Energy use (kWh/year)	Total cost (USD/year)	Pollution reduction (g/year)	Cost effectiveness (USD/g BC)
Slow steaming	3.12E + 07	-2.49E + 06	9.61E + 05	-2.60
WiFE	4.49E + 07	1.19E + 05	1.57E + 06	0.08
LNG	4.49E + 07	-5.01E + 06	2.94E + 06	-1.7
DPF	4.49E + 07	5.63E + 05	2.67E + 06	0.21
SWS	4.49E + 07	4.34E + 05	1.26E + 06	0.35
FWS	4.49E + 07	1.13E + 07	1.26E + 06	8.95

Table 33 – Estimates for the different technologies using MDO fuel cost of 1011.8 USD/mt and a discount rate of 4%

	Energy use (kWh/year)	Total cost (USD/year)	Pollution reduction (g/year)	Cost effectiveness (USD/g BC)
Slow steaming	3.12E + 07	-2.55E + 06	9.61E + 05	-2.65
WiFE	4.49E + 07	9.06E + 04	1.57E + 06	0.06
LNG	4.49E + 07	-5.16E+06	2.94E + 06	-1.76
DPF	4.49E + 07	5.54E + 05	2.67E + 06	0.21
SWS	4.49E + 07	3.54E + 05	1.26E + 06	0.28
FWS	4.49E + 07	1.12E + 07	1.26E + 06	8.89

Table 34 – *Estimates for the different technologies using MDO fuel cost of 320 USD/mt and a discount rate of 7%*

	Energy use (kWh/year)	Total cost (USD/year)	Pollution reduction (g/year)	Cost effectiveness (USD/g BC)
Slow steaming	3.12E + 07	-7.31E + 05	9.61E + 05	-0.76
WiFE	4.49E + 07	7.49E + 04	1.57E + 06	0.05
LNG	4.49E + 07	7.54E + 05	2.94E + 06	0.26
DPF	4.49E + 07	3.25E + 05	2.67E + 06	0.12
SWS	4.49E + 07	2.99E + 05	1.26E + 06	0.24
FWS	4.49E + 07	1.10 + 07	1.26E + 06	8.76

Table 35 – *Estimates for the different technologies using MDO fuel cost of 1213 USD/mt and a discount rate of 7%*

	Energy use (kWh/year)	Total cost (USD/year)	Pollution reduction (g/year)	Cost effectiveness (USD/g BC)
Slow steaming	3.12E + 07	-3.04E + 06	9.61E + 05	-3.16
WiFE	4.49E + 07	1.13E + 05	1.57E + 06	0.07
LNG	4.49E + 07	-6.79E + 06	2.94E + 06	-2.31
DPF	4.49E + 07	6.26E + 05	2.67E + 06	0.23
SWS	4.49E + 07	4.19E + 05	1.26E + 06	0.33
FWS	4.49E + 07	1.13E + 07	1.26E + 06	8.96

Table 36 provides estimates of energy use, total cost of technology, pollution reduction and cost effectiveness when switching from heavy fuel oil (HFO) to MDO. The estimates are made for an engine power of 10,000 kW, total annual operating hours 6,240 and an average engine load fraction of 0.72. The best estimate uses a discount rate of 7%, HFO cost of 659.8 USD/mt and MDO cost of 1011.8 USD/mt (table 36). A sensitivity analysis has been made where the discount rate and the fuel costs are varied. The lowest and the highest MDO price since March 2009 have been used together with the corresponding lowest and highest HFO for the given dates.

Table 36 – *Best estimates when switching from HFO to MDO and sensitivity analysis assessing the impact of changing discount rates and fuel costs*

HFO-> distillate	Energy use (kWh/year)	Total cost (USD/year)	Pollution reduction (g/year)	Cost effectiveness (USD/g BC)
Best estimate	4.49E + 07	2.63E + 06	1.57E + 06	1.67
Interest rate 4%	4.49E + 07	2.63E + 06	1.57E + 06	1.67
Interest rate 10%	4.49E + 07	2.64E + 06	1.57E + 06	1.68
MDO cost 320 USD/mt, HFO cost 160 USD/mt	4.49E + 07	1.28E + 06	1.57E + 06	0.81
MDO cost 1213 USD/mt, HFO cost 903 USD/mt	4.49E + 07	2.14E + 06	1.57E + 06	1.36

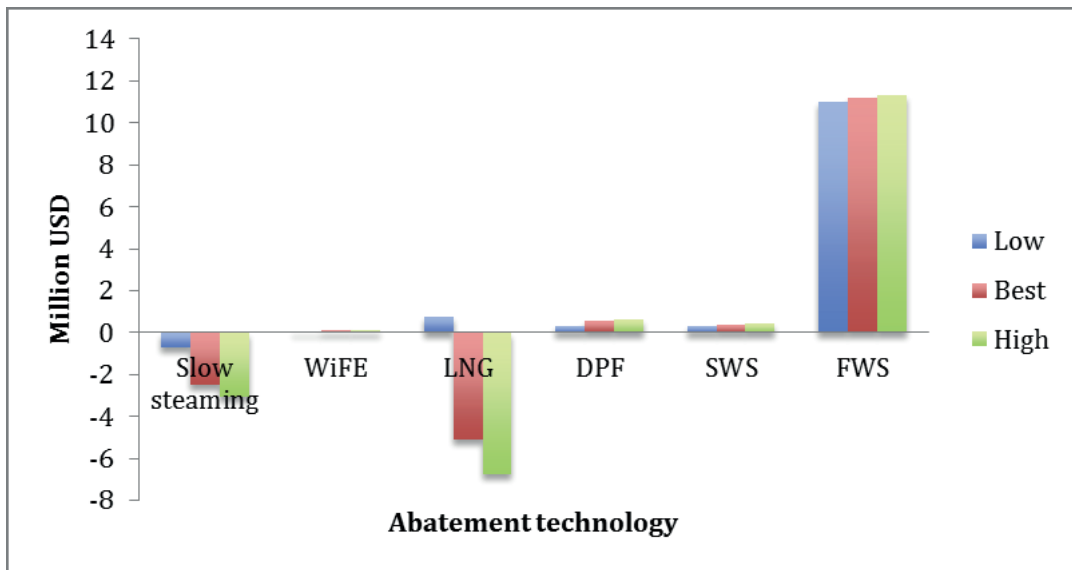

Figure 6: Total costs of the different abatement technologies using the best estimate MDO price of 1,011.8 USD/ton, the lowest MDO price of 320 USD/ton and the highest MDO price of 1,213 USD/ton

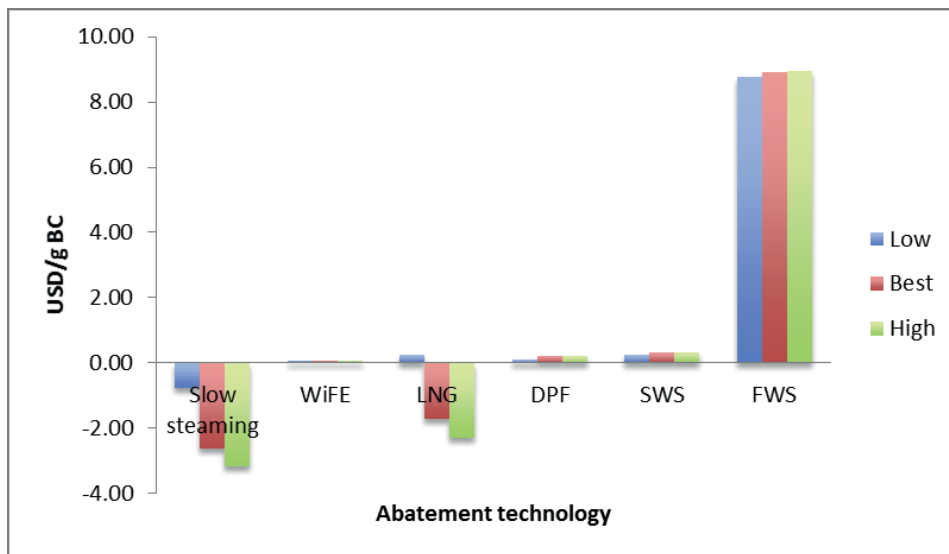

Figure 7: Cost effectiveness of the different abatement technologies using the best estimate MDO price of 1,011.8 USD/ton, the lowest MDO price of 320 USD/ton and the highest MDO price of 1,213 USD/ton

References used for Corbett based calculations

Andersen, M.L., Clausen, N.B. and Sames, P.C., 2011, *LNG as ship fuel*, Germanisher Loyd & MAN, viewed 12 September 2012

http://www.gl-group.com/pdf/GL_MAN_LNG_study_web.pdf (information on costs of equipment and installation when switching to LNG)

Blikom, LP, 2012, Det Norske Veritas, personal communication on lifetime of LNG equipment, Sept. 4th 2012

Blikom, L.P., 2011, *LNG Energy of the future*, Det Norske Veritas, viewed 1 October 2012

<http://blogs.dnv.com/lng/2011/06/which-is-the-cheaper-marine-fuel-oil-or-natural-gas/> (information on LNG cost)

Bunkerindex, 2012, *Index summary*, viewed 12 October 2012

<<http://www.bunkerindex.com/prices/indices.php>>

Bunkerworld, 2012, *Latest prices*, viewed 1 October 2012

<<http://www.bunkerworld.com/prices>>

Corbett, J.J., Winebrake, J.J. & Green, E.H., 2010, 'An assessment of technologies for reducing regional short-lived climate forcers emitted by ships with implications for Arctic shipping', *Future Science – carbon management* (2010) 1(2), 207-225 (specific information on abatement technologies)

<http://www.sjofartsdir.no/PageFiles/7937/An%20assessment%20of%20technologies%20for%20reducing%20regional%20short-lived%20climate%20forces%20emitted%20by%20ships%20with%20implications%20for%20Arctic%20shipping.pdf>

Erria, 2012 (Specific input on slow steaming, switching from HFO and scrubber – appendix E to this study)

Lack, D 2012 (Information on reduction rates when switching from HFO to MDO and when using LNG)

MAN Diesel, 2012, personal communication on lifetime of chiller, 17 October

Pedersen, B.O., 2012, Rolls Royce, personal communication on BC reduction rates for LNG, 10-17 September

Tellkamp, J., 2012, *LNG as a marine fuel*, Det Norske Veritas, viewed 1 October

<http://www.nautischerverein.de/Seiten/schiffstreibstoff_lng.pdf> (information on LNG consumption)

Wils, Y., 2005, *Determination of energy cost of electrical energy on board sea-going vessels*, Ingenieurbüro GmbH & Thermo King Corp., viewed 16 October 2012

http://www.fffship.com/PartnerArea/MiscPresentations/Dr_Wild_Report.pdf (specific information on HFO consumption)

Appendix C
**Cost and BC reduction overview: ship types 10 MW
 with Aframax tanker base case**

**Input
 CAPEX for 10 MW**

	Shaft power (kW) @100% MCR	EEDI (de-rating)		SSDR		WiFE		LNG		DPF		Scrubber	
		Retrofit	New- building	Retrofit	New- building	Retrofit	New- building	Retrofit	New- building	Retrofit	New- building	Retrofit	New- building
1. Aframax	10,000	1,600,000	1,000,000	1,600,000	1,000,000	660,000	260,000	5,350,000	4,550,000	1,030,000	630,000	3,900,000	3,300,000
2. Container	10,000	2,200,000	1,000,000	2,200,000	1,000,000	1,060,000	260,000	6,780,000	5,180,000	1,430,000	630,000	4,500,000	3,300,000
3. Bulk carrier	10,000	1,540,000	1,000,000	1,540,000	1,000,000	620,000	260,000	5,900,000	5,180,000	990,000	630,000	3,840,000	3,300,000
4. Gas	10,000	1,900,000	1,000,000	1,900,000	1,000,000	860,000	260,000	6,380,000	5,180,000	1,230,000	630,000	4,200,000	3,300,000
5. Passenger	10,000	2,800,000	1,000,000	2,800,000	1,000,000	1,460,000	260,000	7,580,000	5,180,000	1,830,000	630,000	5,100,000	3,300,000
6. OSV/AHTS	10,000	2,050,000	1,000,000	2,050,000	1,000,000	960,000	260,000	6,580,000	5,180,000	1,330,000	630,000	4,350,000	3,300,000
7. Tug	10,000	1,300,000	1,000,000	1,300,000	1,000,000	460,000	260,000	5,580,000	5,180,000	830,000	630,000	3,600,000	3,300,000

Addition to OPEX per day for 10 MW

	Shaft power (kW)@90% MCR	EEDI (de-rating)				SSDR			WiFE		LNG comparison			Scrubber	
		2-stroke	4-stroke	4-stroke	2-stroke	2-stroke	4-stroke	4-stroke	30 vol.% H ₂ O	20 vol.% H ₂ O	MGO	HFO	DPF	SW mode	FW mode
1. Aframax	9,000	-1,600	-	-	-1,600	-	-	500	400	-25,500	-13,800	107	400	37,200	
2. Container	9,000	-1,600	-	-	-1,600	-	-	500	400	-25,500	-13,800	107	400	37,200	
3. Bulk carrier	9,000	-1,600	-	-	-1,600	-	-	500	400	-25,500	-13,800	107	400	37,200	
4. Gas	9,000	-1,600	-1,800	-1,800	-1,600	-1,800	-	500	400	-25,500	-13,800	107	400	37,200	
5. Passenger	9,000	-	-1,800	-	-	-1,800	-	600	500	-29,300	-15,800	123	500	37,300	
6. OSV/AHTS	9,000	-	-1,800	-	-	-1,800	-	600	500	-29,300	-15,800	123	500	37,300	
7. Tug	9,000	-	-1,800	-	-	-1,800	-	500	500	-29,300	-15,800	123	500	37,300	

BC reduction rates [g/kWh]

	No abatement	SSDR	WiFE	LNG	DPF	SWS
Low	0	0.001	0.014	0.056	0.049	0.017
Base case	0	0.021	0.035	0.065	0.059	0.028
High	0.000	0.041	0.056	0.070	0.063	0.035

Operating days, interest rate and lifetime

Operating days per year	260
Interest rate	6%
Lifetime year	10
Retrofit	
Newbuilding	30

Calculations

	Shaft power (kW)@90% MCR	EEDI (de-rating)			SSDR		WIFE		LNG comparison			Scrubber	
		2-stroke	4-stroke	2-stroke	4-stroke	30 vol.% H ₂ O	20 vol.% H ₂ O	MGO	HFO	DPF	SW mode	FW mode	
1. Aframax	-416,000	-	-416,000	-	130,000	104,000	-6,630,000	-3,588,000	3,068,000	104,000	9,672,000	-416,000	
2. Container	-416,000	-	-416,000	-	130,000	104,000	-6,630,000	-3,588,000	3,068,000	104,000	9,672,000	-416,000	
3. Bulk carrier	-416,000	-	-416,000	-	130,000	104,000	-6,630,000	-3,588,000	3,068,000	104,000	9,672,000	-416,000	
4. Gas	-416,000	-468,000	-416,000	-468,000	130,000	104,000	-6,630,000	-3,588,000	3,068,000	104,000	9,672,000	-416,000	
5. Passenger	-	-468,000	-	-468,000	156,000	130,000	-7,618,000	-4,108,000	3,536,000	130,000	9,698,000	-	
6. OSV/AHTS	-	-468,000	-	-468,000	156,000	130,000	-7,618,000	-4,108,000	3,536,000	130,000	9,698,000	-	
7. Tug	-	-468,000	-	-468,000	156,000	130,000	-7,618,000	-4,108,000	3,536,000	130,000	9,698,000	-	

Aframax	EEDI (de-rating)	SSDR		WIFE		LNG			DPF		Scrubber	
		30 vol.% H ₂ O	20 vol.% H ₂ O	30 vol.% H ₂ O	20 vol.% H ₂ O	MGO	HFO	DPF	SW mode	FW mode		
Newbuilding	1,000,000	1,000,000	260,000	260,000	4,550,000	4,550,000	630,000	3,300,000	3,300,000	3,300,000	3,300,000	
Addition to OPEX per year (USD)	-416,000	-416,000	130,000	104,000	-6,630,000	-3,588,000	27,749	0	104,000	0	104,000	

Costs

Costs per year for retrofit (USD)

Shaft power (kW)@90% MCR	EEDI (de-rating)	SSDR		WIFE		LNG			DPF		Scrubber	
		30 vol.% H ₂ O	20 vol.% H ₂ O	30 vol.% H ₂ O	20 vol.% H ₂ O	MGO	HFO	DPF	SW mode	FW mode		
1. Aframax	-198,611	-198,611	219,673	193,673	-5,903,106	-2,861,106	167,693	633,885	10,201,885			
2. Container	-117,090	-117,090	274,020	248,020	-5,708,815	-2,666,815	222,040	715,406	10,283,406			
3. Bulk carrier	-206,763	-206,763	214,238	188,238	-5,828,379	-2,786,379	162,258	625,733	10,193,733			
4. Gas	-157,851	-157,851	246,846	220,846	-5,763,162	-2,721,162	194,866	674,645	10,242,645			
5. Passenger	-87,570	-87,570	354,367	328,367	-6,588,121	-3,078,121	280,618	822,927	10,390,927			
6. OSV/AHTS	-189,471	-189,471	286,433	260,433	-6,723,989	-3,213,989	212,684	721,026	10,289,026			
7. Tug	-291,372	-291,372	218,499	192,499	-6,859,857	-3,349,857	144,750	619,125	10,187,125			

Costs per year for newbuilding [USD]

	Shaft power (kW) @90% MCR	EEDI (de-rating)	SSDR		WIFE		LNG			Scrubber	
			30 vol.-% H ₂ O	20 vol.-% H ₂ O	30 vol.-% H ₂ O	20 vol.-% H ₂ O	MGO	HFO	DPF	SW mode	FW mode
1. Aframax	9,000	-343,351	-343,351	148,889	122,889	-6,299,447	-3,257,447	73,518	343,741	9,911,741	
2. Container	9,000	-343,351	-343,351	148,889	122,889	-6,253,679	-3,211,679	73,518	343,741	9,911,741	
3. Bulk carrier	9,000	-343,351	-343,351	148,889	122,889	-6,253,679	-3,211,679	73,518	343,741	9,911,741	
4. Gas	9,000	-343,351	-343,351	148,889	122,889	-6,253,679	-3,211,679	73,518	343,741	9,911,741	
5. Passenger	9,000	-395,351	-395,351	174,889	148,889	-7,241,679	-3,731,679	77,749	369,741	9,937,741	
6. OSV/AHTS	9,000	-395,351	-395,351	174,889	148,889	-7,241,679	-3,731,679	77,749	369,741	9,937,741	
7. Tug	9,000	-395,351	-395,351	174,889	148,889	-7,241,679	-3,731,679	77,749	369,741	9,937,741	

BC reduction overview

Reduction per year (g) per vessel

	Shaft power (kW) @90% MCR	EEDI (de-rating)	SSDR		WIFE		LNG			Scrubber	
			30 vol.-% H ₂ O	20 vol.-% H ₂ O	30 vol.-% H ₂ O	20 vol.-% H ₂ O	MGO	HFO	DPF	SW mode	FW mode
1. Aframax	9,000	-	1,179,360	1,965,600	1,965,600	3,650,400	3,650,400	3,313,440	1,572,480	1,572,480	
2. Container	9,000	-	1,179,360	1,965,600	1,965,600	3,650,400	3,650,400	3,313,440	1,572,480	1,572,480	
3. Bulk carrier	9,000	-	1,179,360	1,965,600	1,965,600	3,650,400	3,650,400	3,313,440	1,572,480	1,572,480	
4. Gas	9,000	-	1,179,360	1,965,600	1,965,600	3,650,400	3,650,400	3,313,440	1,572,480	1,572,480	
5. Passenger	9,000	-	1,179,360	1,965,600	1,965,600	3,650,400	3,650,400	3,313,440	1,572,480	1,572,480	
6. OSV/AHTS	9,000	-	1,179,360	1,965,600	1,965,600	3,650,400	3,650,400	3,313,440	1,572,480	1,572,480	
7. Tug	9,000	-	1,179,360	1,965,600	1,965,600	3,650,400	3,650,400	3,313,440	1,572,480	1,572,480	
1 Aframax	9,000	-	1,179,360	1,965,600	1,965,600	3,650,400	3,650,400	3,313,440	1,572,480	1,572,480	
Decrease low		-	1,123,200	1,179,360	1,179,360	505,440	505,440	561,600	617,760	0	
Increase high		-	2,504,736	3,066,336	3,066,336	2,639,520	2,639,520	2,347,488	1,572,480	1,572,480	

Cost per BC reduction overview
Cost per reduction for retrofit, base case (USD/g BC)

	Shaft power (kW) @90% MCR	EEDI (de-rating)	SSDR	WIFE		LNG		DPF	Scrubber	
				30 vol.% H ₂ O	20 vol.% H ₂ O	MGO	HFO		SW mode	FW mode
1. Aframax	9,000	-	-0.17	0.11	0.10	-1.62	-0.78	0.05	0.40	6.49
2. Container	9,000	-	-0.10	0.14	0.13	-1.56	-0.73	0.07	0.45	6.54
3. Bulk carrier	9,000	-	-0.18	0.11	0.10	-1.60	-0.76	0.05	0.40	6.48
4. Gas	9,000	-	-0.13	0.13	0.11	-1.58	-0.75	0.06	0.43	6.51
5. Passenger	9,000	-	-0.07	0.18	0.17	-1.80	-0.84	0.08	0.52	6.61
6. OSV/AHTS	9,000	-	-0.16	0.15	0.13	-1.84	-0.88	0.06	0.46	6.54
7. Tug	9,000	-	-0.25	0.11	0.10	-1.88	-0.92	0.04	0.39	6.48
1 Aframax	9,000	-	-0.17	0.11	0.10	-1.62	-0.78	0.05	0.40	6.49
Decrease low		-	3.37	-0.17	-0.15	0.26	0.13	-0.01	-0.26	0.00
Increase high		-	0.11	-0.07	-0.06	0.68	0.33	-0.02	-0.20	-3.24

Cost per reduction for newbuilding, base case [USD/g BC]

	Shaft power (kW) @90% MCR	EEDI (de-rating)	SSDR	WIFE		LNG		DPF	Scrubber	
				30 vol.% H ₂ O	20 vol.% H ₂ O	MGO	HFO		SW mode	FW mode
1. Aframax	9,000	-	-0.29	0.08	0.06	-1.73	-0.89	0.02	0.22	6.30
2. Container	9,000	-	-0.29	0.08	0.06	-1.71	-0.88	0.02	0.22	6.30
3. Bulk carrier	9,000	-	-0.29	0.08	0.06	-1.71	-0.88	0.02	0.22	6.30
4. Gas	9,000	-	-0.29	0.08	0.06	-1.71	-0.88	0.02	0.22	6.30
5. Passenger	9,000	-	-0.34	0.09	0.08	-1.98	-1.02	0.02	0.24	6.32
6. OSV/AHTS	9,000	-	-0.34	0.09	0.08	-1.98	-1.02	0.02	0.24	6.32
7. Tug	9,000	-	-0.34	0.09	0.08	-1.98	-1.02	0.02	0.24	6.32
1 Aframax	9,000	-	-0.29	0.08	0.06	-1.73	-0.89	0.02	0.22	6.30
Decrease low		-	5.82	-0.11	-0.09	0.28	0.14	0.00	-0.14	0.00
Increase high		-	0.20	-0.05	-0.04	0.72	0.37	-0.01	-0.11	-3.15

Figures – 10 MW comparison

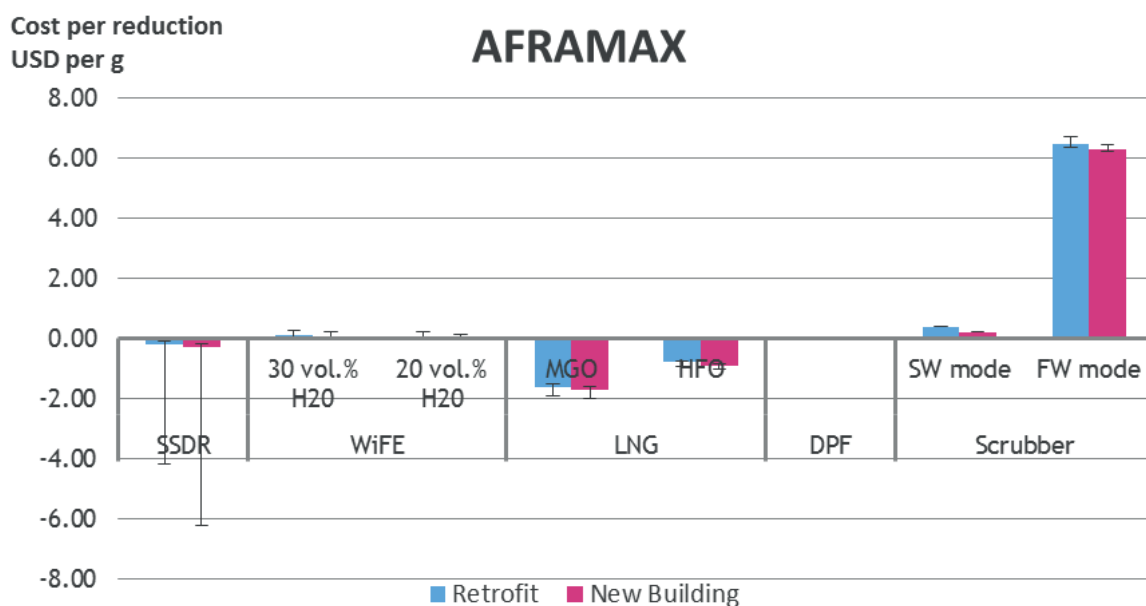
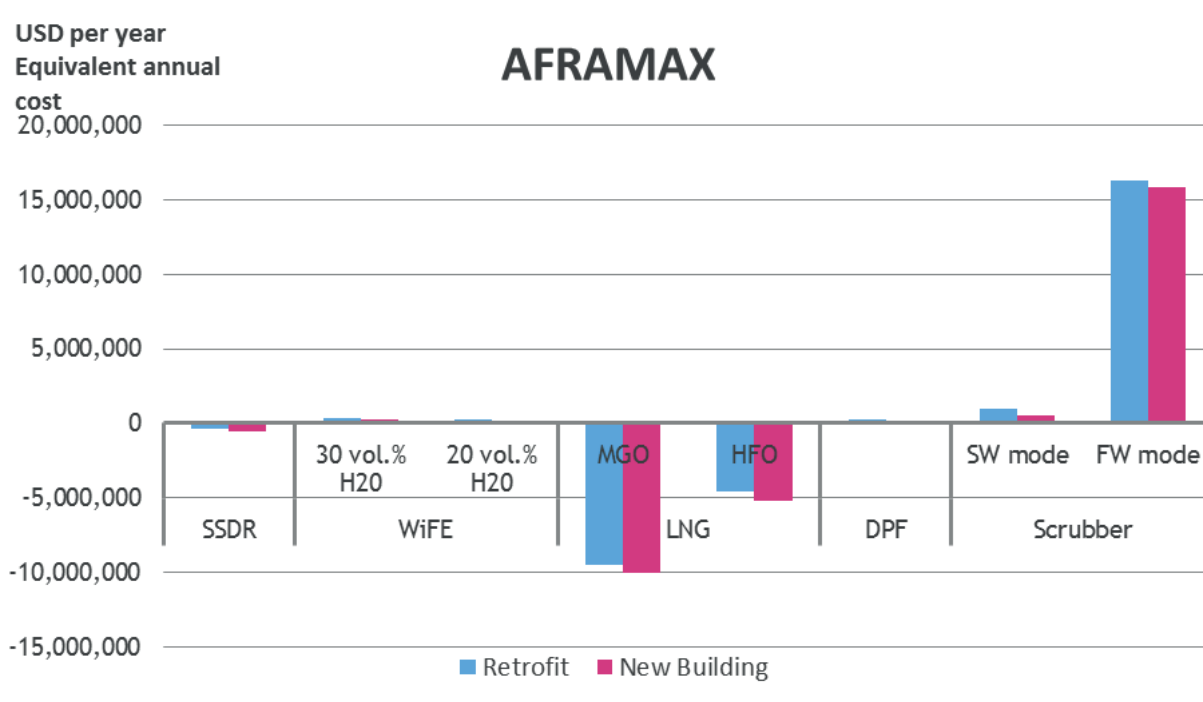

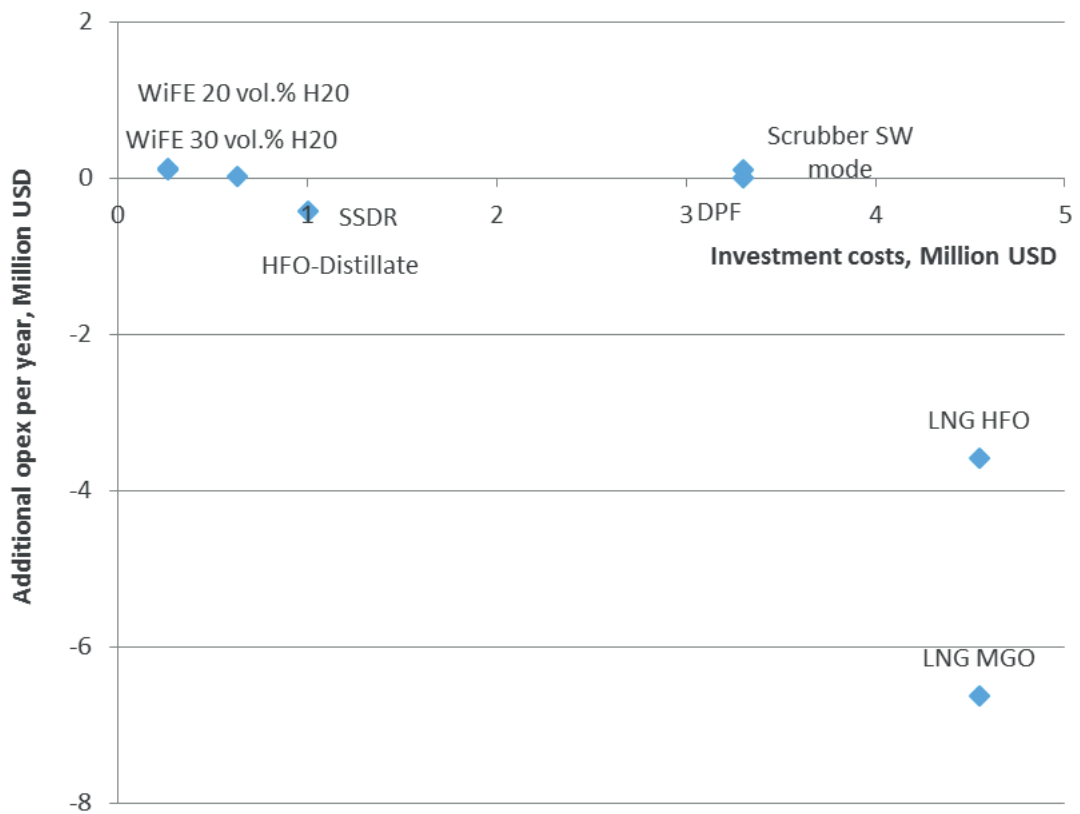
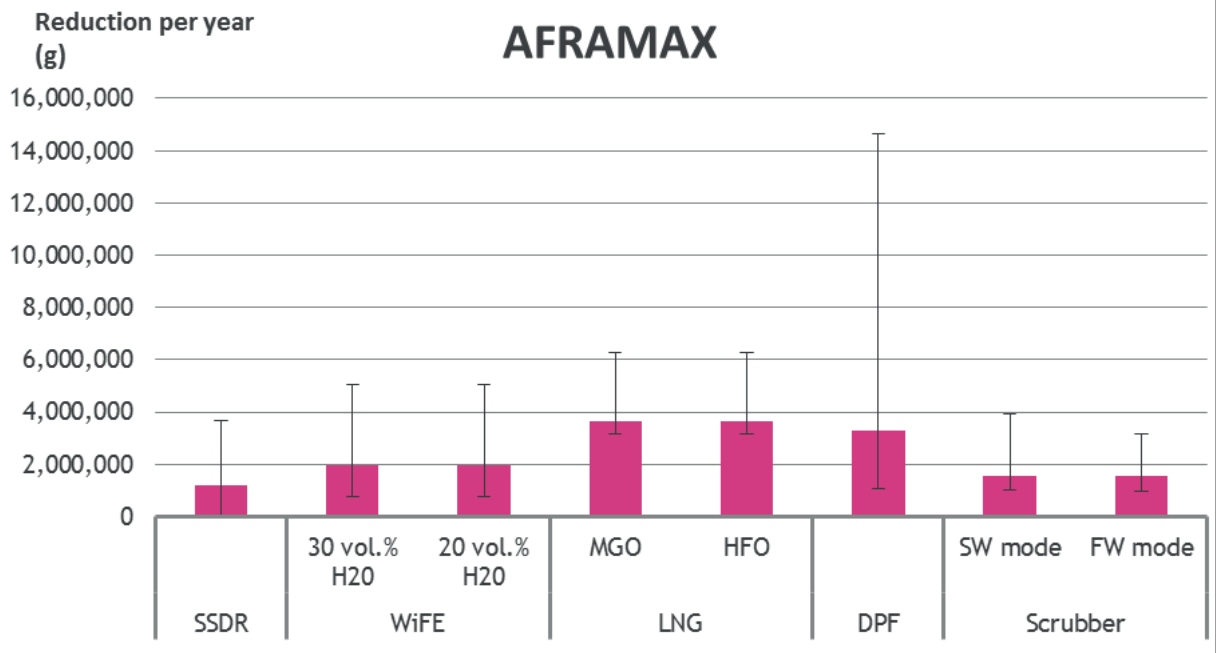

Appendix D Cost and BC reduction overview: similar docking size; varying MW Input data, CAPEX

Input

	Shaft power (kW) @100% MCR	EEDI (de-rating)		SSDR		WiFE		LNG		DPF		Scrubber	
		Retrofit	Newbuilding	Retrofit	Newbuilding	Retrofit	Newbuilding	Retrofit	Newbuilding	Retrofit	Newbuilding	Retrofit	Newbuilding
1. Aframax	16,000	2,210,000	1,610,000	2,210,000	1,610,000	810,000	410,000	8,080,000	7,280,000	1,410,000	1,010,000	5,880,000	5,280,000
2. Container	76,500	9,730,000	8,530,000	9,730,000	8,530,000	2,970,000	2,170,000	45,630,000	44,030,000	6,160,000	5,360,000	29,240,000	28,040,000
3. Bulk carrier	13,500	2,050,000	1,510,000	2,050,000	1,510,000	740,000	380,000	8,490,000	7,770,000	1,310,000	950,000	5,490,000	4,950,000
4. Gas	19,800	3,110,000	2,210,000	3,110,000	2,210,000	1,160,000	560,000	12,600,000	11,400,000	1,990,000	1,390,000	8,160,000	7,260,000
5. Passenger	67,500	9,330,000	7,530,000	9,330,000	7,530,000	3,120,000	1,920,000	41,250,000	38,850,000	5,930,000	4,730,000	26,540,000	24,740,000
6. OSV/AHTS	14,400	2,660,000	1,610,000	2,660,000	1,610,000	1,110,000	410,000	9,690,000	8,290,000	1,710,000	1,010,000	6,330,000	5,280,000
7. Tug	5,490	910,000	610,000	910,000	610,000	360,000	160,000	3,560,000	3,160,000	580,000	380,000	2,310,000	2,010,000

Input data, addition to OPEX per day

	Shaft power (kW)@90% MCR	EEDI (de-rating)				SSDR		WiFE		LNG comparison			Scrubber	
		2-stroke	4-stroke	2-stroke	4-stroke	2-stroke	4-stroke	30 vol.% H ₂ O	20 vol.% H ₂ O	MGO	HFO	DPF	SW mode	FW mode
1. Aframax	14,400	-2,600	-	-2,600	-	-	900	600	-40,800	-22,000	171	700	59,500	
2. Container	76,500	-13,600	-	-13,600	-	-	4,500	3,400	-216,600	-117,100	907	3,600	316,100	
3. Bulk carrier	13,500	-2,400	-	-2,400	-	-	800	600	-38,200	-20,700	160	600	55,800	
4. Gas	19,800	-3,500	-4,000	-3,500	-4,000	-	1,200	900	-56,100	-30,300	235	900	81,800	
5. Passenger	67,500	-	-13,800	-	-13,800	-	4,600	3,400	-219,500	-118,600	919	3,700	279,900	
6. OSV/AHTS	14,400	-	-2,900	-	-2,900	-	1,000	700	-46,800	-25,300	196	800	59,700	
7. Tug	5,490	-	-1,100	-	-1,100	-	400	300	-17,900	-9,600	75	300	22,800	

Operating days per year

260

Interest rate

6%

Lifetime year

Retrofit

10

Newbuilding

30

Calculations

Addition to OPEX per year [USD]

	Shaft power (kW) @90% MCR	EEDI (de-rating)		SSDR		WiFE		LNG comparison			Scrubber	
		2-stroke	4-stroke	2-stroke	4-stroke	30 vol.% H ₂ O	20 vol.% H ₂ O	MGO	HFO	DPF	SW mode	FW mode
1. Aframax	14,400	-676,000	-	-676,000	-	234,000	156,000	-10,608,000	-5,720,000	44,398	182,000	15,470,000
2. Container	76,500	-3,536,000	-	-3,536,000	-	1,170,000	884,000	-56,316,000	-30,446,000	235,865	936,000	82,186,000
3. Bulk carrier	13,500	-624,000	-	-624,000	-	208,000	156,000	-9,932,000	-5,382,000	41,623	156,000	14,508,000
4. Gas	19,800	-910,000	-1,040,000	-910,000	-1,040,000	312,000	234,000	-14,586,000	-7,878,000	61,048	234,000	21,268,000
5. Passenger	67,500	-	-3,588,000	0	-3,588,000	1,196,000	884,000	-57,070,000	-30,836,000	238,991	962,000	72,774,000
6. OSV/AHTS	14,400	-	-754,000	0	-754,000	260,000	182,000	-12,168,000	-6,578,000	50,985	208,000	15,522,000
7. Tug	5,490	-	-286,000	0	-286,000	104,000	78,000	-4,654,000	-2,496,000	19,438	78,000	5,928,000

Aframax	EEDI (de-rating)	SSDR		WiFE		LNG			DPF		Scrubber	
		1,610,000	-676,000	410,000	234,000	30 vol.% H ₂ O	20 vol.% H ₂ O	MGO	HFO	1,010,000	44,398	5,280,000
Newbuilding	1,610,000	1,610,000	-676,000	410,000	234,000	410,000	7,280,000	7,280,000	1,010,000	44,398	5,280,000	5,280,000
Addition to OPEX per year (USD)	-676,000	-676,000	-676,000	234,000	234,000	156,000	-10,608,000	-5,720,000	44,398	44,398	0	182,000

Cost overview

Costs per year retrofit

	Shaft power (kW) @90% MCR	EEDI (de-rating)	SSDR		WIFE		LNG		DPF		Scrubber	
			30 vol.% H ₂ O	20 vol.% H ₂ O	30 vol.% H ₂ O	20 vol.% H ₂ O	MGO	HFO	DPF	SW mode	FW mode	
1. Aframax	14,400	-375,732	-375,732	344,053	266,053	-9,510,187	-4,622,187	235,972	980,904	16,268,904		
2. Container	76,500	-2,214,005	-2,214,005	1,573,528	1,287,528	-50,116,345	-24,246,345	1,072,812	4,908,779	86,158,779		
3. Bulk carrier	13,500	-345,471	-345,471	308,542	256,542	-8,778,481	-4,228,481	219,610	901,915	15,253,915		
4. Gas	19,800	-487,451	-487,451	469,607	391,607	-12,874,064	-6,166,064	331,425	1,342,683	22,376,683		
5. Passenger	67,500	-2,320,352	-2,320,352	1,619,908	1,307,908	-51,465,447	-25,231,447	1,044,688	4,567,936	76,379,936		
6. OSV/AHTS	14,400	-392,591	-392,591	410,813	332,813	-10,851,439	-5,261,439	283,319	1,068,044	16,382,044		
7. Tug	5,490	-162,360	-162,360	152,912	126,912	-4,170,310	-2,012,310	98,241	391,855	6,241,855		

Costs per year newbuilding

	Shaft power (kW) @90% MCR	EEDI (de-rating)	SSDR		WIFE		LNG		DPF		Scrubber	
			30 vol.% H ₂ O	20 vol.% H ₂ O	30 vol.% H ₂ O	20 vol.% H ₂ O	MGO	HFO	DPF	SW mode	FW mode	
1. Aframax	14,400	-559,035	-559,035	263,786	185,786	-10,079,116	-5,191,116	117,774	565,586	15,853,586		
2. Container	76,500	-2,916,305	-2,916,305	1,327,648	1,041,648	-53,117,268	-27,247,268	625,264	2,973,075	84,223,075		
3. Bulk carrier	13,500	-514,300	-514,300	235,607	183,607	-9,367,518	-4,817,518	110,640	515,612	14,867,612		
4. Gas	19,800	-749,446	-749,446	352,683	274,683	-13,757,802	-7,049,802	162,030	761,431	21,795,431		
5. Passenger	67,500	-3,040,954	-3,040,954	1,335,486	1,023,486	-54,247,590	-28,013,590	582,620	2,759,334	74,571,334		
6. OSV/AHTS	14,400	-637,035	-637,035	289,786	211,786	-11,565,741	-5,975,741	124,360	591,586	15,905,586		
7. Tug	5,490	-241,684	-241,684	115,624	89,624	-4,424,429	-2,266,429	47,045	224,024	6,074,024		

BC Reduction Overview

Reductions per year (g) per vessel

	Shaft power (kW) @90% MCR	EEDI (de-rating)	SSDR	WtE		LNG			Scrubber	
				30 vol.:% H ₂ O	20 vol.:% H ₂ O	MGO	HFO	DPF	SW mode	FW mode
1. Aframax	14,400	-	1,886,976	3,144,960	3,144,960	5,840,640	5,840,640	5,301,504	2,515,968	2,515,968
2. Container	76,500	-	10,024,560	16,707,600	16,707,600	31,028,400	31,028,400	28,164,240	13,366,080	13,366,080
3. Bulk carrier	13,500	-	1,769,040	2,948,400	2,948,400	5,475,600	5,475,600	4,970,160	2,358,720	2,358,720
4. Gas	19,800	-	2,594,592	4,324,320	4,324,320	8,030,880	8,030,880	7,289,568	3,459,456	3,459,456
5. Passenger	67,500	-	8,845,200	14,742,000	14,742,000	27,378,000	27,378,000	24,850,800	11,793,600	11,793,600
6. OSV/AHTS	14,400	-	1,886,976	3,144,960	3,144,960	5,840,640	5,840,640	5,301,504	2,515,968	2,515,968
7. Tug	5,490	-	719,410	1,199,016	1,199,016	2,226,744	2,226,744	2,021,198	959,213	959,213
1 Aframax	14,400	-	1,886,976	3,144,960	3,144,960	5,840,640	5,840,640	5,301,504	2,515,968	2,515,968
Decrease low		-	1,797,120	1,886,976	1,886,976	808,704	808,704	898,560	988,416	0
Increase high		-	1,797,120	1,886,976	1,886,976	449,280	449,280	359,424	628,992	628,992

Cost per BC Reduction Overview

Costs per reduction retrofit (USD/g)

	Shaft power (kW) @90% MCR	EEDI (de-rating)	SSDR	WtE		LNG			Scrubber	
				30 vol.:% H ₂ O	20 vol.:% H ₂ O	MGO	HFO	DPF	SW mode	FW mode
1. Aframax	14,400	-	-0.20	0.11	0.08	-1.63	-0.79	0.04	0.39	6.47
2. Container	76,500	-	-0.22	0.09	0.08	-1.62	-0.78	0.04	0.37	6.45
3. Bulk carrier	13,500	-	-0.20	0.10	0.09	-1.60	-0.77	0.04	0.38	6.47
4. Gas	19,800	-	-0.19	0.11	0.09	-1.60	-0.77	0.05	0.39	6.47
5. Passenger	67,500	-	-0.26	0.11	0.09	-1.88	-0.92	0.04	0.39	6.48
6. OSV/AHTS	14,400	-	-0.21	0.13	0.11	-1.86	-0.90	0.05	0.42	6.51
7. Tug	5,490	-	-0.23	0.13	0.11	-1.87	-0.90	0.05	0.41	6.51
1 Aframax	14,400	-	-0.20	0.11	0.08	-1.63	-0.79	0.04	0.39	6.47
Decrease low		-	3.98	-0.16	-0.13	0.26	0.13	-0.01	-0.25	0.00
Increase high		-	0.10	-0.04	-0.03	0.12	0.06	0.00	-0.08	-1.29

Costs per reduction newbuilding (USD/g)

	Shaft power (kW) @90% MCR	EEDI (de-rating)	SSDR	WIFE		LNG			Scrubber	
				30 vol.% H ₂ O	20 vol.% H ₂ O	MGO	HFO	DPF	SW mode	FW mode
1. Aframax	14,400	-	-0.30	0.08	0.06	-1.73	-0.89	0.02	0.22	6.30
2. Container	76,500	-	-0.29	0.08	0.06	-1.71	-0.88	0.02	0.22	6.30
3. Bulk carrier	13,500	-	-0.29	0.08	0.06	-1.71	-0.88	0.02	0.22	6.30
4. Gas	19,800	-	-0.29	0.08	0.06	-1.71	-0.88	0.02	0.22	6.30
5. Passenger	67,500	-	-0.34	0.09	0.07	-1.98	-1.02	0.02	0.23	6.32
6. OSV/AHTS	14,400	-	-0.34	0.09	0.07	-1.98	-1.02	0.02	0.24	6.32
7. Tug	5,490	-	-0.34	0.10	0.07	-1.99	-1.02	0.02	0.23	6.33
1 Aframax	14,400	-	-0.30	0.08	0.06	-1.73	-0.89	0.02	0.22	6.30
Decrease low		-	5.93	-0.13	-0.09	0.28	0.14	0.00	-0.15	0.00
Increase high		-	0.14	-0.03	-0.02	0.12	0.06	0.00	-0.04	-1.26

Figures

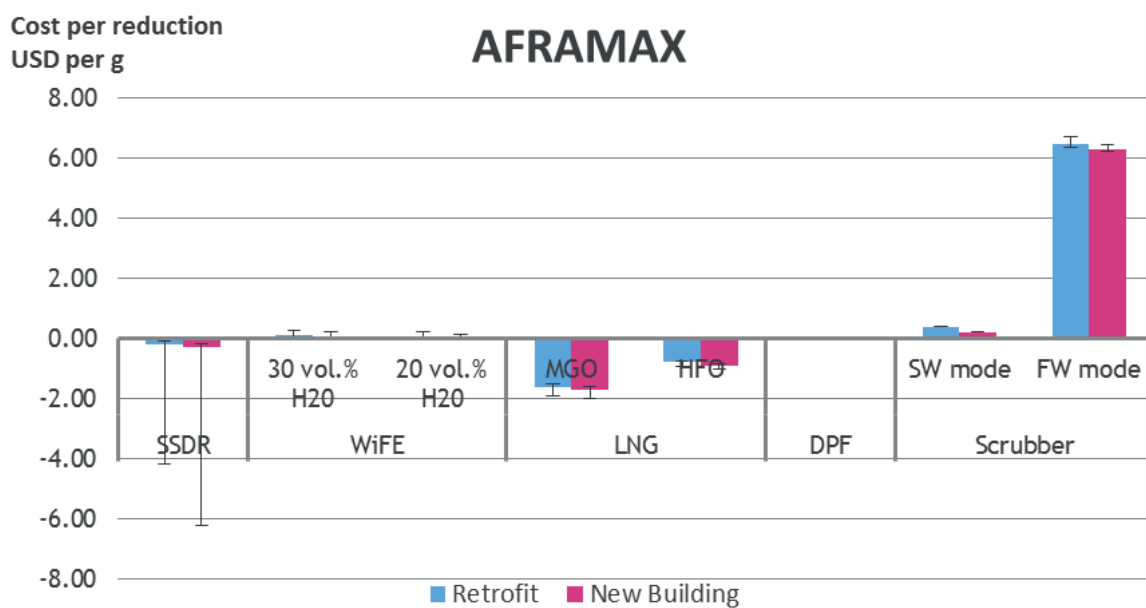
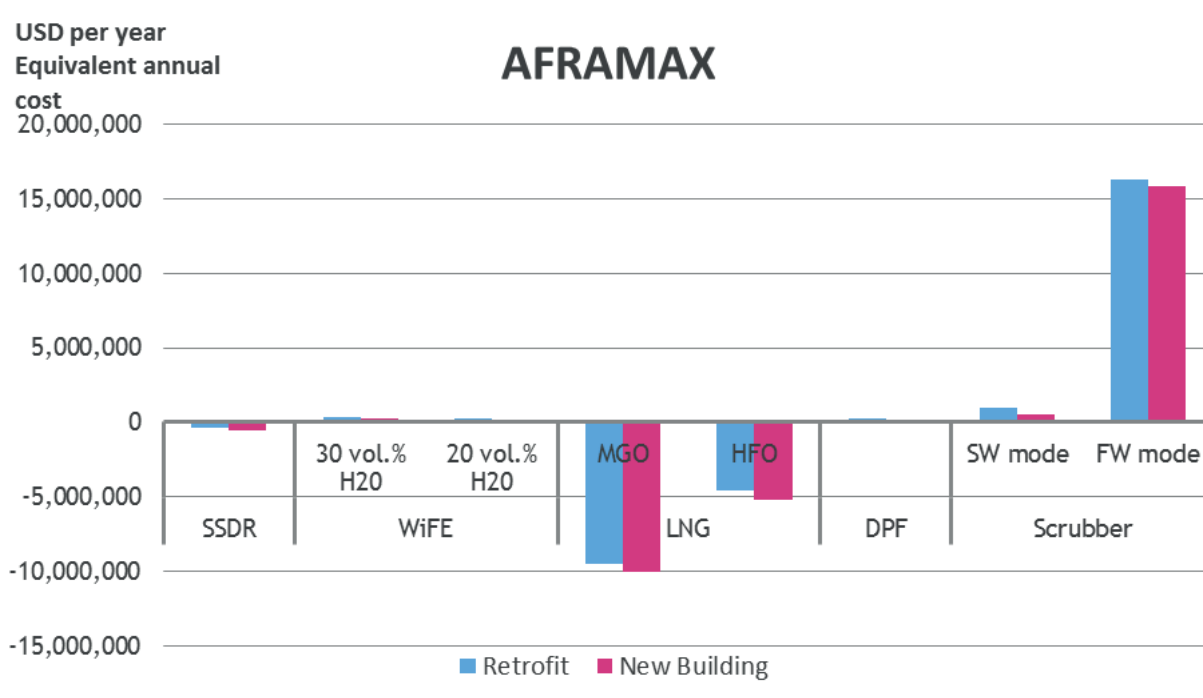

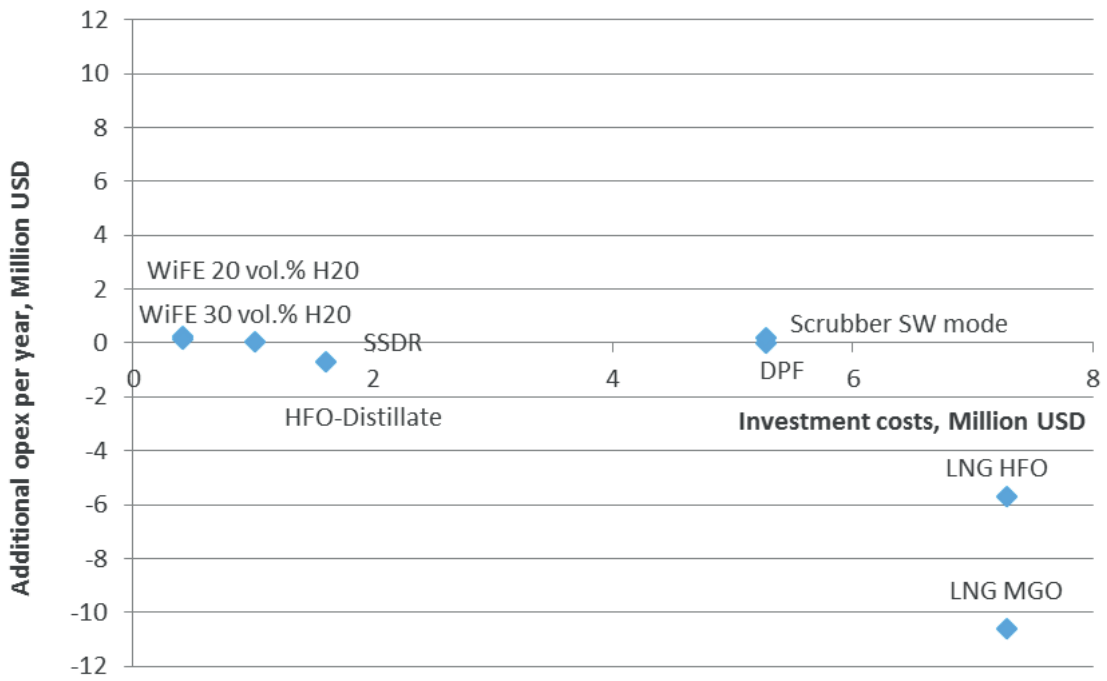
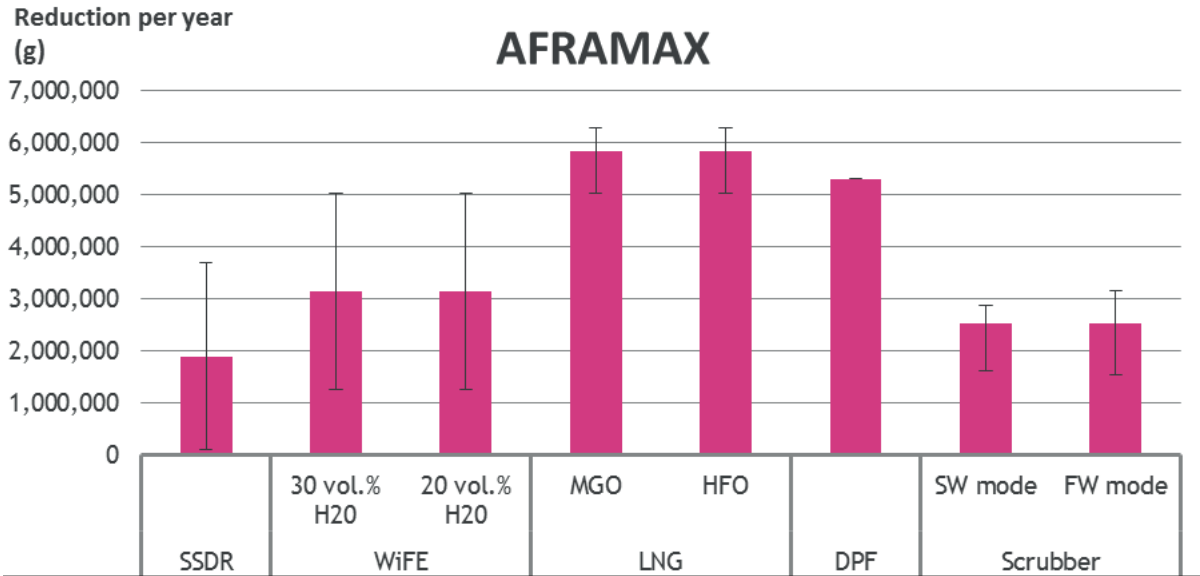

Appendix E

Extract of Erria report

(IMPORTANT: tables in this appendix are extracted from the full Erria report (not reproduced) and so table and figure numbers in appendix E **are not sequential** to the table and figure numbers in the main report)

1 Introduction

The below technical and cost analysis report has the intention of clarifying and cost evaluating the selected seven abatement measures available on the market to reduce Black Carbon (BC). The selected abatement measures are applied to the Base Case, Aframax Tanker as listed in table 34, where we have summarized and calculated capital investment cost and application to seven vessels, of which five similar capacity vessels and two smaller but also very relevant vessels were selected. The five vessels are similar in capacity but have very different power requirements, due to application and speed requirement. After analysing costs of the equipment from different makers, we could conclude that there was a linear relationship between price of the equipment and the power of the main engine, except for the EEDI, which is dependent on other parameters as well. The procedure to estimate the cost for each vessel type, was to take quotes from makers and calculate a rough cost, USD/kW, for each abatement measure and scale up or down to the relevant vessel. We would like to advise that the estimates could vary 10% to –20%.

The capital investment of the abatement measures is approximately 80% to 90% of the total retrofitting cost, which makes it quite irrelevant in which part of the world the equipment is installed. The charter rates of each vessel type was also taken into consideration, as we estimated some of the retrofitting cases to take up to 40 days, which is a considerable cost to consider. Our conclusion is that, if possible, the abatement measures are to be installed at newbuilding stage to reduce the CAPEX, between 40% to 60%, depending on off-hire rates and installation time. During the design phase of a newbuilding, many of the smaller modifications to the standard design can be absorbed into the contract price. The cost difference between newbuilding and retrofitting is illustrated in table 35.

Consideration for the additional operating costs per day have also been taken into account and illustrated in table 35. The reason for not including the vessel's individual OPEX is simply because the different vessels and owners/managers, use different nationalities of crew, which could influence the OPEX drastically. Crewing costs are often approximately 50% of the total OPEX of a vessel, depending on complexity and Flag of Registration.

Table 9 – Fuel price – world wide

	HFO 380 1–3.5%S	MGO 0.1%S	LNG
Singapore	USD 676.00	USD 995.00	USD 412.00
Rotterdam	USD 653.50	USD 975.00	USD 389.00
Houston	USD 671.50	USD 1,040.00	
Fujairah	USD 681.50	USD 1,026.00	
Los Angeles	USD 686.50	USD 1,097.00	
Durban		USD 1,131.50	
Tokyo	USD 718.50	USD 1,008.00	
New York	USD 663.50		
Average:	USD 678.71	USD 1,038.93	USD 400.50

2 EEDI (Energy Efficiency Design Index)

At the intersessional meeting in Norway 2008, the concept of the Energy Efficiency Design Index was introduced for the first time. The concept is a bit controversial as EEDI can be lowered, simply by reducing the speed, even though the propulsion efficiency is low. However, in order to obtain the lowest possible EEDI at the highest speed, the total propulsion efficiency shall be as high as possible. Several attempts have been made to make EEDI speed independent. There are three major means to reduce EEDI: speed reduction, decrease in steel weight and increase in length.

When considering the options to reduce the EEDI and taking into consideration the limitations of retrofitting an abatement measure, we chose slow steaming: with de-rating, where the same number of off-hire days as per the de-rating case were used. This solution is one of the most effective solutions to reduce EEDI with one of the lowest CAPEXs, if having to retrofit. If your vessel has an electronic engine, your CAPEX will be reduced approximately 45% to 50% compared to the Standard Mechanical Injection Engine (e.g. MC, MC-C or RTA).

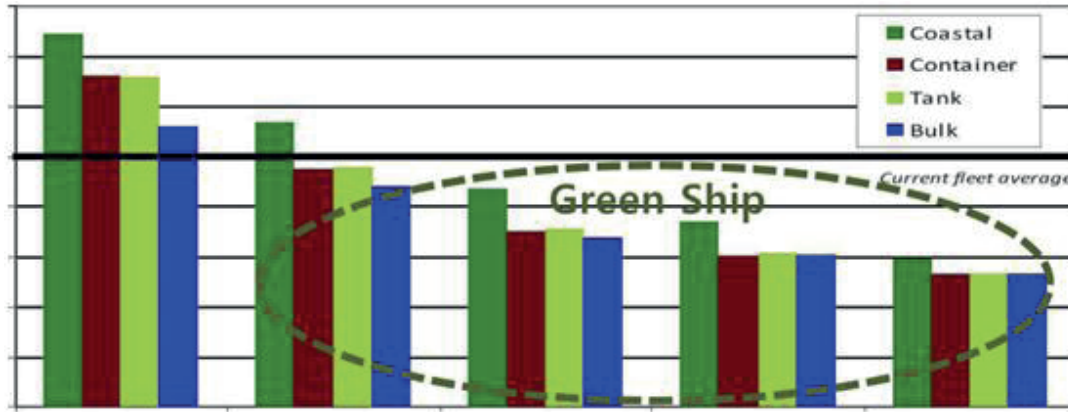

Figure 4: Estimated required EEDI

EEDI base line definition

$$EEDI \text{ value} = CF \cdot \frac{SFC_{ME} \cdot \sum_{j=1}^{NME} P_{MEi} + SFC_{AE} \cdot P_{AE}}{Capacity \cdot V_{ref}}$$

- $CF_{ME} = CF_{AE} = CF = 3.1144 \text{ g CO}_2/\text{g fuel}$
- $SFC_{ME} = 190 \text{ g/kWh}$
- $SFC_{AE} = 215 \text{ g/kWh}$
- $P_{MEi} = 0.75 \cdot MCR_i$
- $(MCR) > 10,000 \text{ kW: } P_{AE} = 250 + 0.025 \cdot \sum_{j=1}^{NMEi} MCR_{MEi}$
- $(MCR) \leq 10,000 \text{ kW: } P_{AE} = 0.05 \cdot \sum_{j=1}^{NMEi} MCR_{MEi}$

EEDI – Definitions

V_{ref} is the ship speed, measured in nautical miles per hour (knot), on deep water in the condition corresponding to the Capacity as defined in paragraph 1 – 4 below at the shaft power of the engine(s) corrected for PTI and PTO and assuming the weather is calm with no wind and no waves.

Capacity is defined as follows:

- 1 For bulk carriers, tankers, gas tankers, ro-ro cargo, general cargo ships, refrigerated cargo carrier and combination carriers, deadweight should be used as Capacity.
- 2 For passenger ships and ro-ro passenger ships, gross tonnage in accordance with the International Convention of Tonnage Measurement of Ships 1969, Annex I, regulation 3 should be used as Capacity.
- 3 For containerships, 70% of the deadweight should be used as Capacity.
- 4 Deadweight means the difference in tonnes between the displacement of a ship in water of relative density of 1,025 kg/m³ at the summer load draught and the lightweight of the ship. The summer load draught should be taken as the maximum summer draught as certified in the stability booklet approved by the administration or an organization recognized by it.

Figure 5: EEDI (Base line definition)⁽ⁱ⁾

Additional requirements and restrictions

- IMO 15 July 2011: Mandatory measures to reduce emissions of greenhouse gases (GHGs) from international shipping were adopted.
- The Amendments to MARPOL Annex VI Regulations for the prevention of air pollution from ships, scheduled to enter into force on 1 January 2013, add a new chapter 4 to Annex VI on Regulations on energy efficiency for ships to make mandatory the Energy Efficiency Design Index (EEDI), for new ships, and the Ship Energy Efficiency Management Plan (SEEMP) for all ships.
- EEDI only applies to new vessels, which could give an unfair advantage to vessels built before 1 January 2013, due to the fact that the EEDI restricted vessels will possibly be forced to operate at lower speeds and forcing the owner to introduce more vessels into a trading pattern to move the same amount of cargo during a limited amount of time. The capital investment for the EEDI restricted vessels are estimated to be 25% to 30%, which will reduce their profit margin compared to existing vessels. The fuel savings with EEDI implementation measures in many cases do not benefit the owners, as it is the charterer or operator that procures the fuel.
- No limitations for polar operation.
- No limitations in respect to Class rules on the listed vessels.

3 Slow steaming: with de-rating

Slow steaming was started during the end of 2007 by mainly container vessel owners and operators, when the charter rates dropped drastically at the beginning of the financial downturn in the US. Vessels were instructed by owners to reduce main engine load to approximately 40% MCR, which decreased the speed with approximately 20%. An average FOC (Fuel Oil Cost) saving of approximately 42% without de-rated engine and 45% with a de-rated motor can be calculated below in table 22, Slow steaming (40% MCR) without and with de-rated engine.

Table 22 – *Slow steaming (40%MCR) without and with de-rated engine*

Shaft power	Speed (knots)	Distance (nautical miles)	Time	Total fuel consumption	Fuel oil	Savings (%)
90% MCR (kW)	14256	15,0	10000	667	1730	0%
40% MCR (kW) without derating	6336	11,4	10000	877	1012	42%
40% MCR (kW) with derating	6336	11,4	10000	877	951	45%

From January 2010, owners started to investigate super slow steaming, down to below 35% MCR, as low as 10% MCR. Engine makers were initially hesitant due to the lack of experience but in June 2011, MAN Diesel issued a Service Letter (SL11-544 MTS) permitting owners to reduce engine load down to 10% MCR with certain recommendations. Several problems arise with low load operation, e.g. loss of Main Engine Turbocharger and propeller efficiency, fouling of hull, economizer soot build-up, etc. Electronic engines (ME, ME-B and RT-FLEX) are more flexible for slow steaming, therefore it is recommended to convert all mechanical injection Main engines to electronically controlled engines.⁽ⁱⁱ⁾

This conversion is costly, estimated at approximately USD 100 USD / kW, including slide fuel valves, which are highly recommended by engine makers.

A Danish initiative, Green Ship of the Future, presented in Copenhagen 2012, a Vessel Emission Study,^[130] where MAN Diesel estimated the conversion cost of the MT Nord Butterfly from a MC engine (Mechanical Injection) to a ME-B engine (Electrohydraulic, common rail injection). The conversion was from a 6S50MC-C (9.480 kW) motor to a 6S50ME-B, with the same effect. With our experience from MAN Diesel retrofits, it is possible to calculate a table 30, Cost per kW, to scale the CAPEX to the specific vessel in table 34. If your vessel already has installed an Electronic engine, your CAPEX will be reduced approximately 45% to 50%.

Table 23 – *Green Ship of the Future: Vessel Emission Study (Copenhagen 2012)^[130]*

NORD Butterfly ME-B Conversion	9480	kW
CAPEX	USD 800,000	
Cost per kW for ME-B conversion	84	USD/kW

Engine makers are offering de-rated engines from newbuilding, where there is a larger CAPEX but reducing the SFOC by 3% to 6% reduces the fuel costs. If the propeller is redesigned to a more flexible operating curve, a further 6% to 10% can be achieved, resulting in a total SFOC reduction of 10% to 15%.⁽ⁱⁱ⁾ Only reduced SFOC was included into table 35, Addition to OPEX (USD/day).

When slow steaming, less cargo is transported from point A to B, thus additional vessels need to be included to transport the same amount of cargo as the ships operating at normal speeds. We have not included this scenario into table 22, Slow steaming (40% MCR) without and with de-rated engine due its complexity. Only the reduced fuel consumption with a de-rated engine is included into.

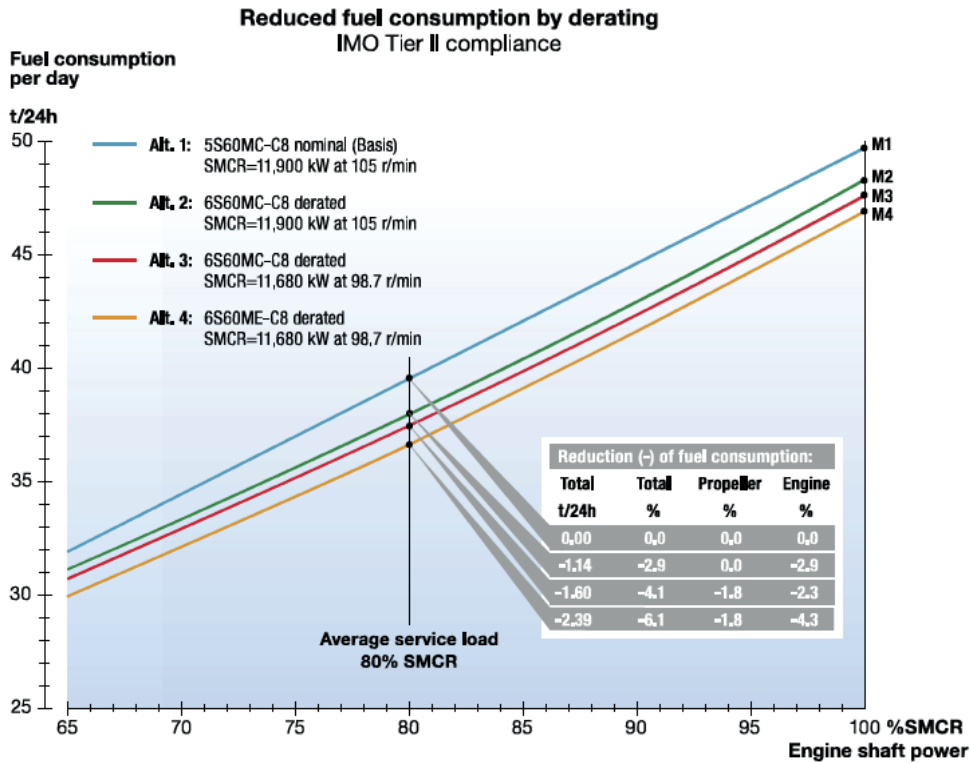

Figure 6: De-rated S60MC MAN Diesel Engine⁽ⁱⁱ⁾

CO₂ index from FORCE study

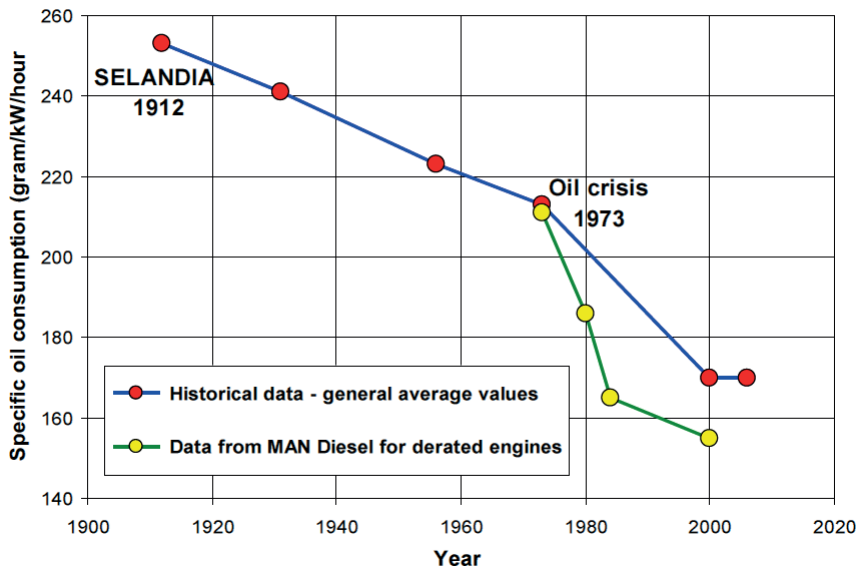

Figure 7: SFOC reduction past 100 years⁽ⁱⁱⁱ⁾

Additional requirements and restrictions

- Guidance from Lloyds Register⁽ⁱⁱⁱ⁾

If the de-rated engines have been de-rated after delivery, a new de-rated certificate has to be issued which would have to comply with NO_x requirements as per MEPC.1/Circ.678.^(iv) Unusually, for such requirements, the certification can be undertaken by the Administration of any signatory to MARPOL Annex VI and hence this will not necessarily be a particular ship’s flag State. In practice it is probable

that, as with much of the NO_x Technical Code certification, the actual approval will be undertaken by one of the Recognized Organizations acting on behalf of an Administration (Classification Society).

- No polar limitations.

4 Water-in-Fuel Emulsion (WiFE)

In WiFE water is added continuously to the fuel supply and a homogeneous mixture is ensured by mechanical measures. When the mixture is injected the additional heat required to heat up liquid water to the boiling point, the evaporation itself, as well as the super heating of the water vapour significantly lowers the combustion temperatures, and hence the NO_x formation. Previous experience shows that as a rule of thumb the NO_x emission is reduced approximately 1% per 1% water present in the mixture (on a total mass basis) (Eckert, Velji, & Spicher, 2007).^(v) Some deviation from this rule of thumb has been observed (Henningesen, 1994; Pedersen, Andreasen, & Mayer, 2010)^(v) thus it should not be taken too literally and applicable to any condition.

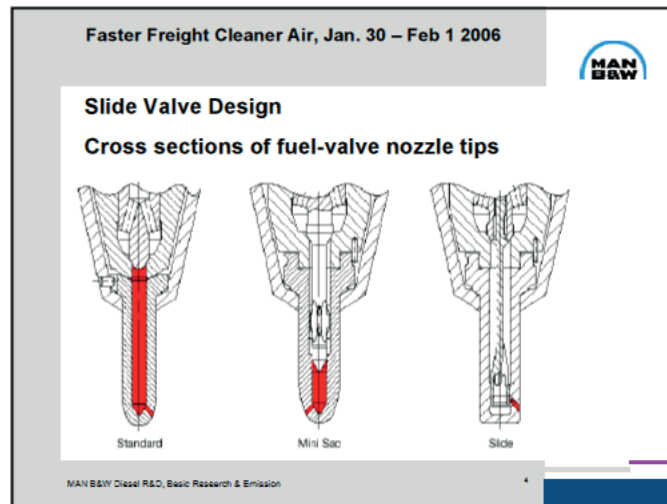

Figure 8: Slide fuel valve (MAN Diesel)^(vi)

To retrofit a WiFE system to a standard engine the following components need to be installed or replaced.

- A Homogenizer unit, which heats the water and mixes it with fuel to form an emulsion prior injection, is to be installed. A presentation by MAN Diesel in 2006, estimated a cost of USD 400.000 investment excl. retrofit on a 40.000 kW engine.^(vi) We estimate a 20% price increase from 2006 to 2012, this gives a USD/kW estimate of approximately USD 12/kW. If we include retrofitting costs but excl. off-hire, we can expect an average cost per kW of USD 27/kW. On the Aframax Tanker base case we estimated a retrofit time of 20 days with an off-hire rate of USD 20.000/day, which increases the cost per kW to USD 52/kW.

Table 24 – MAN Diesel: emulsion cost overview^(vi)

Engine power	40,000	kW
Emulsifier unit cost and slide fuel valves	USD 500,000	
Cost per kW	13	USD/kW

- A possible increase in freshwater (FW) storage capacity on board, as standard FW generator cannot keep up with the FW consumption of the WiFE system thus additional FW is to be stored on board.
- Slide fuel valves are to replace the standard fuel valve (fuel injector), due to the more efficient atomization of the fuel and optimizing the combustion. The cost of the new slide fuel valves are included in the total cost as per table 24, MAN Diesel: Emulsion cost overview.^(vi)

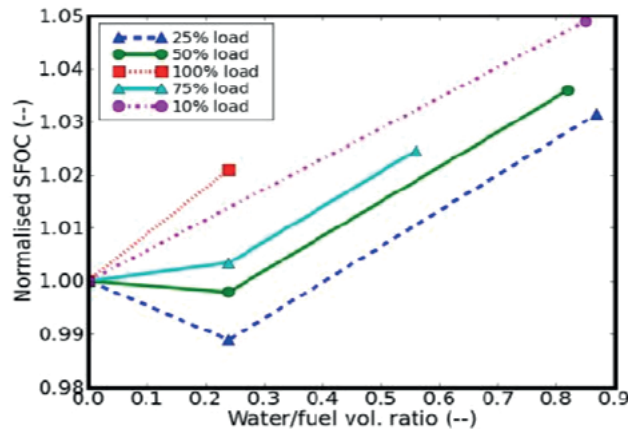

Figure 9: SFOC – vol. % added H₂O

The SFOC (Specific Fuel Oil Consumption) is shown as a function of applied water content at various engine loads in figure 9, SFOC – vol. % added H₂O. It is observed that the SFOC generally increases for the larger additions of water. This is due to energy required to heat up the injected water to its saturation temperature, subsequent evaporation at the saturation temperature and further super heating to the temperature in the combustion zone. In previous work, the SFOC penalty at 30 vol. % added water is estimated to be approximately 2,8% when considering evaporation and super heating only. It should be noted that the water may contribute with work in the expansion process thereby reducing the actual SFOC penalty.

Another recent unpublished estimate taking the heating of water in the liquid phase to saturation temperature and subsequent evaporation (neglecting super heating) and taking the expansion work into account leads to a SFOC penalty of approx. 1,5% at 30 vol. % water added. We have estimated an approximate 2% penalty at 30 vol. % water added, table 25, Additional energy consumption of WiFE, which is included in table 35, additions to OPEX.

Table 25 – Additional energy consumption of WiFE^(vi)

SFOC Penalty 20 vol. % H ₂ O	
SFOC increase @ 20 vol. % H ₂ O added	1,5%
SFOC increase @ 30 vol. % H ₂ O added	2,0%

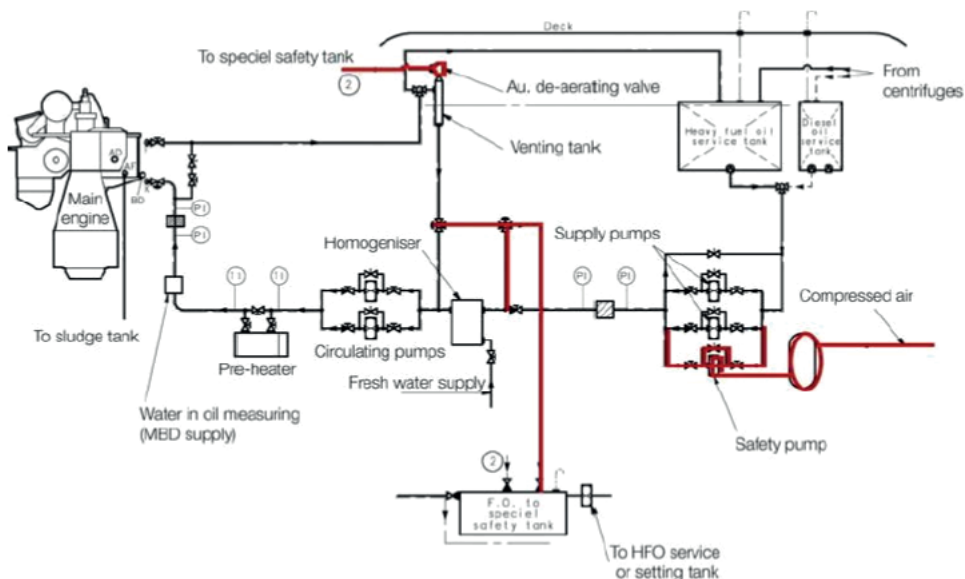

Figure 10: WiFE layout^(vi)

Additional requirements and restrictions

- The WiFE application is still fairly new, thus little is known about the corrosive effects the water will have on the fuel system, and other machinery related to the fuel system.
- When operating on MGO instead of HFO emulsion, it is recommended to add additives to stabilize the emulsion.
- The installation is to comply with IMO Tier III requirements. The engine maker or equipment manufacturer will test and issue certification.
- Freshwater tank volume of up to 50% of the fuel tank volume.
- Possible installation of additional freshwater generators if freshwater tank volume is limited.
- No polar restrictions, except heating is required in the freshwater tanks and piping to avoid freezing.
- No Classification Society restrictions.

5 LNG

Liquefied Natural Gas (LNG) is lighter than air and has a narrow flammability interval. It can be combusted in 2-stroke gas engines as diesel cycle and in 4-stroke, applying the Otto principle. 2-Stroke slow speed engines are generally only using diesel fuel as pilot fuel (functioning on heat of compression and not with a spark plug).

The 2-stroke engines can operate on diesel fuel only but at low loads, due to the fact that the pilot fuel valves are di-mensioned only for efficient operation between 1% to 20% diesel fuel, depending on engine load, when at low load operation the pilot fuel ratio to LNG is approximately 5% to 20% but as the load increases the ratio drops to as low as 1%.

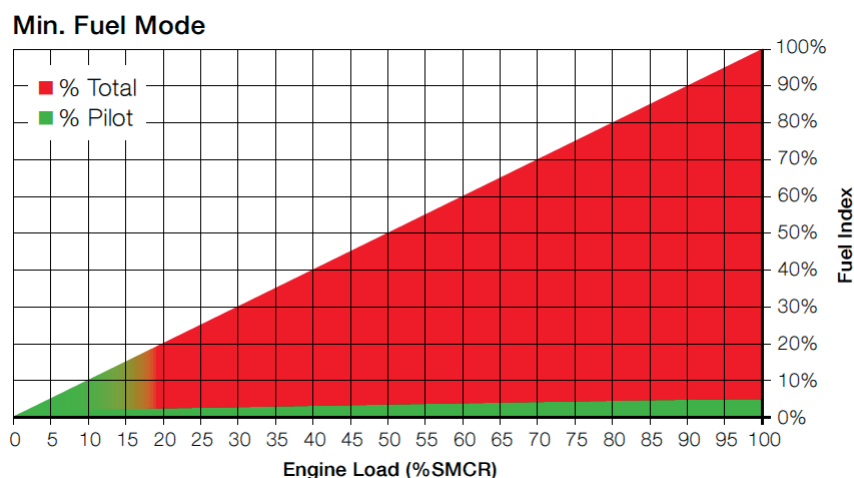

Figure 11: MAN ME-GI dual fuel engines

Dual fuel 4-stroke medium speed LNG engines are based upon the Otto technology. The primary fuel is natural gas but they are designed to operate interchangeably with diesel as a 'pilot' ignition source (functioning on heat of compression and not with a spark plug). These engines can also operate on 100% diesel fuel. When idling these engines tend to operate on 100% diesel. As the engine begins to move to full load performance, an increasing amount of natural gas replaces the diesel fuel to 90% or more.

This makes LNG engines especially valuable in circumstances where the use of natural gas is desired for environmental or economic reasons but if the natural gas supply is not available in all locations, the engines can run on Pilot MGO. (2-stroke engines will only be able to run at approximately 50% load because the Pilot fuel system only supplies 20% fuel.)

Generally the larger vessels with constant load and RPM use the 2-stroke LNG engines and the variable load vessels, e.g. cruise liners, supply vessels and tugs will use the 4-stroke dual fuel engines, with diesel electric propulsion units for better efficiency. Exhaust gas emissions such as SO_x and PM are negligible. LNG contains less carbon than fuel oils, reducing the CO₂ emissions first and foremost from tank to propeller. Liquefied Natural Gas (LNG) is natural gas stored as liquid at -162°C. The predominant component is methane with some ethane and small amounts of heavy hydrocarbons.

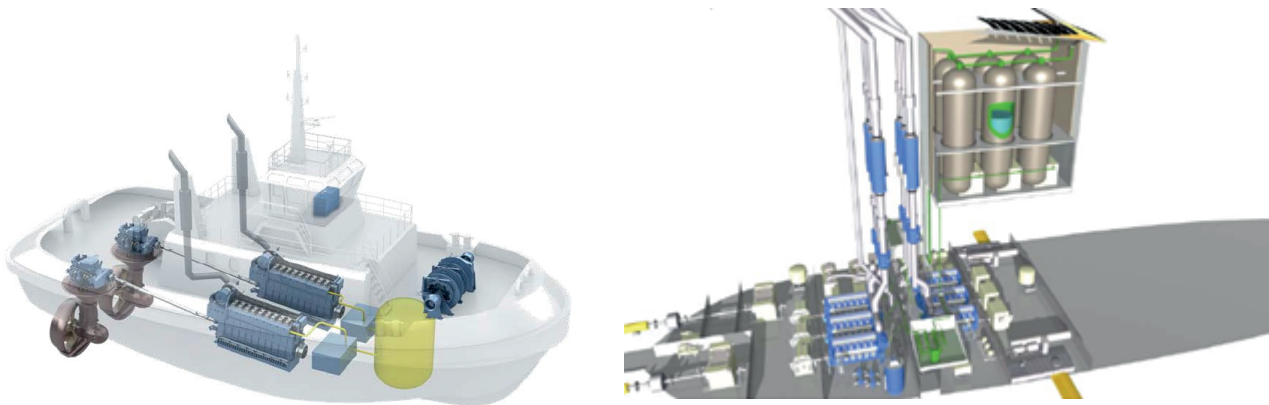

Figure 12: *LNG Installation on Harbour Tug and Cruise Liner (Rolls Royce & Wartsila)*

The LNG tank volume is selected to give the AFRAMAX base case vessel half-round-trip endurance. This controls investment costs but increases exposure to volatile fuel prices. Costs for LNG system include costs for the tanks, bunker station, gas preparation (cryogenic plant), gas line, main engine (electronic controlled common rail (ME-B) conversion). If the existing engine is an electronic controlled common rail engine (ME-B, RT-Flex), the cost saving could be up to 20%.

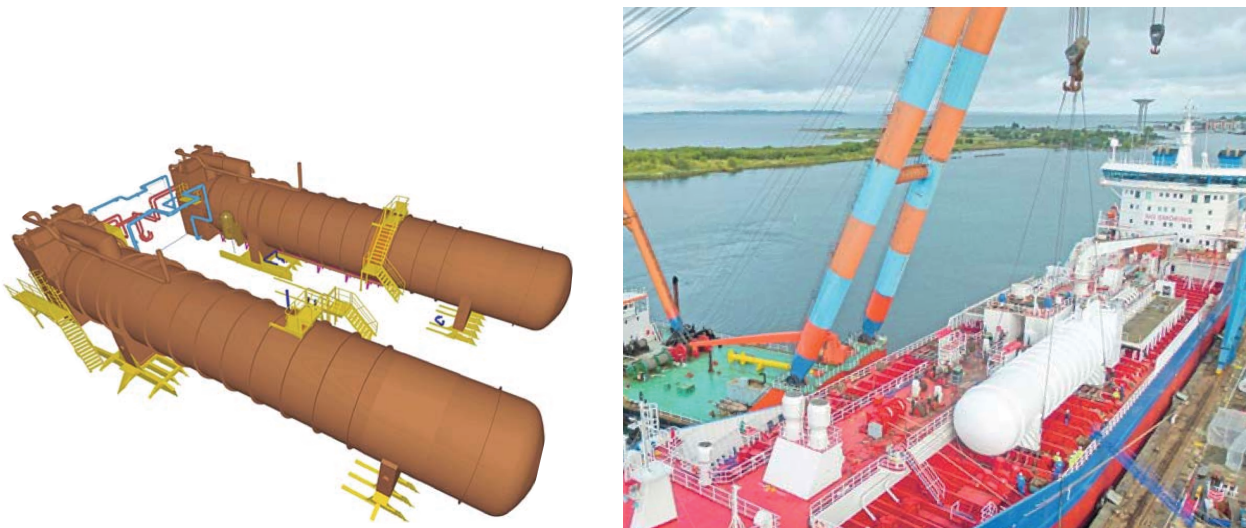

Figure 13: *LNG Fuel Tank installation on a tanker vessel^(vii)*

Due to the low temperature, LNG has to be stored in cryogenic tanks. LNG storage tanks require double the space compared to traditional fuel oil tanks. For the AFRAMAX base case vessel, where the HFO capacity is approximately 1000 m³, where the replacement LNG capacity is estimated to 2000 m³, in our table 26, LNG conversion estimates. We have received estimates from MAN Diesel and GL^(viii) for the construction cost of LNG tanks. Estimates from USD 1000/m³ to USD 5000/m³ for the LNG tanks. The AFRAMAX tanker LNG tank cost was estimated at USD 1000/m³ but becomes more costly if the tanks cannot be installed on the main deck. For example, cruise liners, container vessels, bulk carriers, LNG tankers and supply vessels will need more complicated shapes to fulfil space restrictions. The LNG tank cost was estimated at USD 1500/m³. Some vessels will experience reduced cargo capacity in some cases, depending on type of vessel, type of fuel tank and potential for adequate location of the LNG tanks on board. LNG tanks are assumed to consume TEU slots on container vessels, resulting in lost earnings, assumed only for every second voyage. The large-sized container vessels (8 500 TEU and 15 000 TEU) have losses with a maximum of about 1,5% of the total available TEU slots.

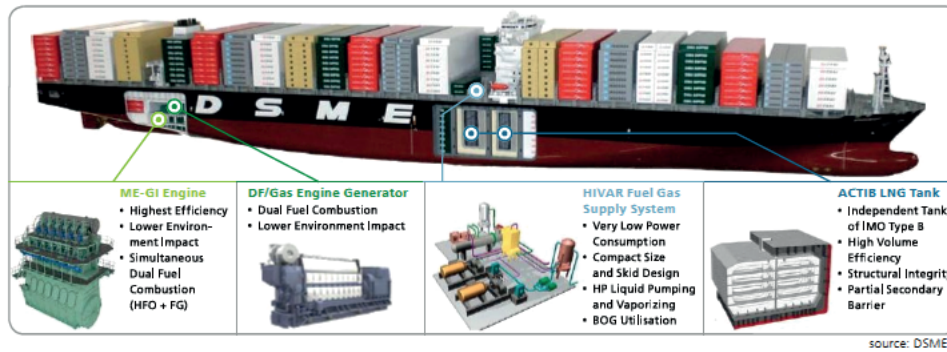

Figure 14: LNG layout on board a Large Container vessel^(ix)

A cryogenic plant is required to pump the LNG fuel from the fuel tanks at a pressure. LNG has a high auto ignition temperature and therefore needs an additional ignition source, i.e. a pilot fuel, to ignite in combustion engines. Expected MGO consumption (pilot fuel) 1% to 5% & cryogenic plant fuel consumption penalty of 1,2%. We have used 2% for pilot fuel consumption and a total fuel penalty of 3,2% in table 26, LNG conversion estimates. The cryogenic plant is reported by MAN Diesel to cost approximately USD 1.500.000 (for our base case AFRAMAX Tanker), which were used in table 34, CAPEX.

The following large costs are involved with the LNG installation on AFRAMAX:

Table 26 – LNG conversion estimates

Cryogenic plant	USD 1.500.000
LNG tank cost per m ³	USD 1.000
LNG tank capacity	2000 m ³
LNG machinery conversion	42 USD/kW

The bigger needed volume of LNG fuel tanks is one of the disadvantages of LNG use. The localization of LNG fuel tanks can take into account the ship type and safety requirements. The largest share of the additional investment is related to the LNG tank. Average costs are between USD 1000/m³ and USD 5000/m³. For the AFRAMAX, bulk carrier, LNG tanker, OSV and tug, USD 1000/m³ was used but for more complex container and cruise liner, USD 1500/m³ was used.

The price of LNG depended for many years on HFO price, but often is cheaper. Taken into account the cost of LNG is about 60% of HFO. On gas carriers the cost of boil-off gas is decreasing due to savings of re-liquefaction process. Natural gas prices (including LNG) have been reduced the last couple of years due to the introduction of shale gas in the US market. This is a reason that LNG has improved its competitiveness to HFO, especially in ECA areas, where SO_x and NO_x regulations have been enforced. The basic question is what will be the price of HFO in the future. We must remember the middle of 2008 when the price of HFO IFO380 was over 1000 \$ per metric ton. In the middle of 2011 it was about 650 \$ as in 2007 and first half-year 2008, figure 15, LNG prices compared with HFO and MGO (GL). It can be seen that there is a trend for an increasing price of MDO and MGO fuels. In our opinion the price of LNG will be more stable than HFO, because it depends on the industry price.

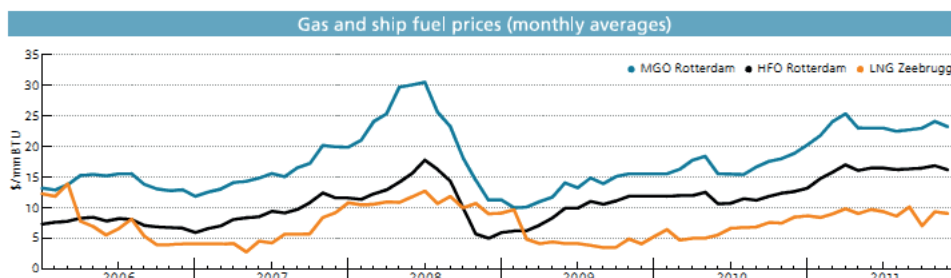

Figure 15: LNG prices compared with HFO and MGO (GL)^(viii)

MGO seems to be an attractive wait-and-see strategy with low investment costs for shipowners who believe that LNG may have a breakthrough sometime in the mid-term future; however, if many shipowners use that strategy the MGO demand – and hence price – will increase (and LNG development may be slower).

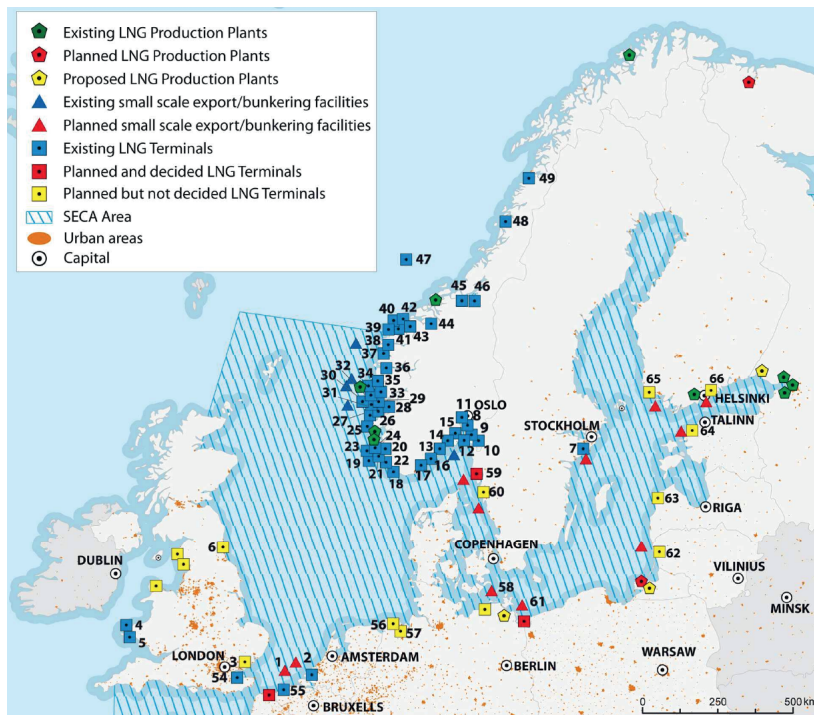

Figure 16: Existing and planned production plants and LNG terminals in the SECA

Additional requirements and restrictions

- The IMO Interim Guidelines for gas as ship fuel (resolution MSC.285 (86)) contain the state of the art on safety concepts for using gas as a ship fuel. These are voluntary to the flag States. GL (Germanische Lloyd) issued its own guidelines in April 2010, adding its own interpretations. The IMO subcommittee BLG is working on the International Gas as Fuel Code (IGF) which will supersede the interim guidelines and which is planned to enter into force with the SOLAS 2014 edition. In parallel, work has started at ISO TC 67 on standards for LNG bunkering.
- LNG supply is under rapid development in the SECA, figure 16, Existing and planned production plants and LNG terminals in the SECA, but is rarely available as bunker fuel outside of EU. Singapore is developing a large terminal for local land-based supply, which could possibly be extended to marine fuel supply, as it is one of the world's largest bunker ports.

Other operational costs (OPEX), such as crew, spare parts and maintenance are assumed to be 10% higher than the standard fuel oil fuelled vessels. This cost is not included in table 35, due to the complexity of OPEX calculations, e.g. different nationalities, trade routes and flag registry.

- Some vessels will experience reduced cargo capacity, depending on type of vessel, type of fuel tank and potential for adequate location of the LNG tanks on board, due to the fact that LNG requires twice the space of fuel oil.
- No polar restrictions.

6 HFO – heavy fuel oil (residual fuel oil) – MGO (distillate fuel):

Running on distillate fuels for a long period of time is the straightforward solution to comply with the forthcoming emission regulations on maximum allowable sulphur content in the fuel oil and reduction of BC.

There are two main challenges when running on MGO: fuel viscosity and main engine cylinder lubrication.^(x)

The fuel systems for engines, boilers and other machinery required to comply with above IMO regulation would be recommended to have a cooler or a chiller arrangement fitted, to meet the fuel viscosity requirements for a safe operation of the engine's fuel system. Vessels in the future will probably not experience problems running without a chiller due to the fact that engine and pump makers are designing their equipment to run on the lower viscosity fuels, but it is not recommended due to increased wear on fuel systems. Cooling of the MGO is a not a straightforward solution since several parameters should be considered before deciding the appropriate method of cooling.

- There are three methods that can cool the MGO in order to increase its viscosity to at least 3 cSt in order to be handled by the pumps without leakages.
- Cooling by sea water coolers
- **Cooling by refrigerating compressors of direct expansion connected by a cooler (chosen solution for our CAPEX)**
- Cooling using water chillers in connection with coolers.

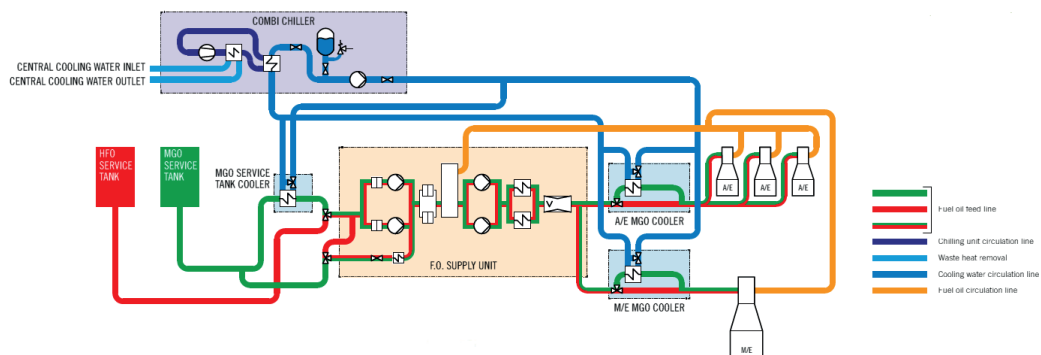

Figure 17: MGO chiller plant layout

Example 1

When MGO 2 cSt @40°C is used and 3 cSt Viscosity is required the temperature is to be cooled to approximately 18°C.

Example 2

MGO with viscosity of 3 cSt @ 40°C is entering the engines at 55°C. According to the curves the viscosity is then between 2 and 3 cSt, approximately 2,3 cSt.

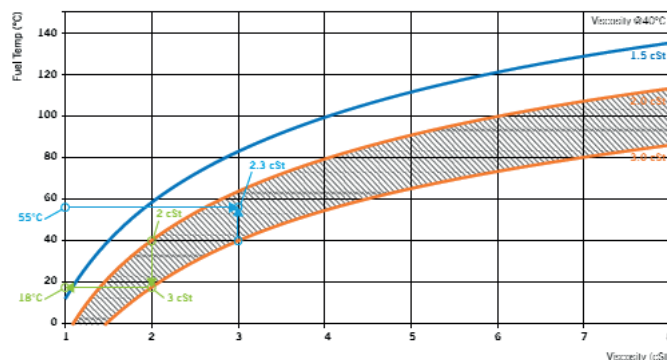

Figure 18: Fuel temperature vs. viscosity

Depending on the installation, the viscosity of MGO should be minimum, 2-3cSt for optimal operation of fuel pumps and fuel valves. The examples below refer to figure 18, Fuel temperature vs. viscosity.

There is a correlation between low sulphur fuels and BN or TBN (Base Number), thus when using low sulphur fuels below 1% sulphur, the cylinder lubrication rate is to be lowered to the minimum dosage, recommended by engine makers, but if using BN 70, the liner would be overadditivated. Therefore engine makers recommend

changing to low BN cylinder Lub oils of BN 40-50 if using low sulphur fuels below 1% sulphur for prolonged periods of time. Automatic cylinder feed rate regulating systems, e.g. Alfa Lubricator, are recommended on newer engines to regulate the dosage automatically during different engine loads.^(x)

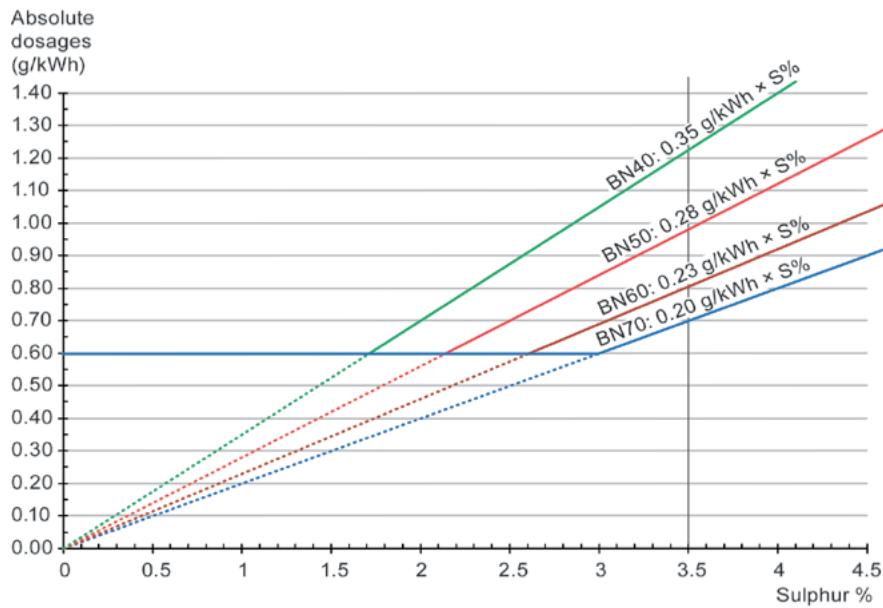

Figure 19: Use of BN40, BN50, BN60 and BN70 cylinder oils

In the shipping field the following type of classification is used for fuel oils (<http://en.wikipedia.org/wiki/Shipping>):

CCAI and CII are two indexes which describe the ignition quality of residual fuel oil, and CCAI is especially often calculated for marine fuels. Despite this marine fuels are still quoted on the international bunker markets with their maximum viscosity (which is set by the ISO 8217 standard) due to the fact that marine engines are designed to use different viscosities of fuel. The unit of viscosity used is the cSt and the fuels most frequently quoted are listed below in order of cost, the least expensive first.

- IFO 380 – Intermediate fuel oil with a maximum viscosity of 380 cSt (<3.5% sulphur)
- LS 380 – Low-sulphur (<1.0%) intermediate fuel oil with a maximum viscosity of 380 cSt
- MDO – Marine diesel oil
- MGO – Marine gas oil
- LSMGO – Low sulphur (<0.1%) marine gas oil – the fuel is to be used in EU community ports and anchorages. *EU Sulphur directive 2005/33/EC*

A chiller unit costs approximately USD 70.000 for the Aframax, which is USD 4/kW for the chiller unit. The calculated cost per kW for the chiller unit and installation is USD 13/kW excluding the expected 10 off-hire days. This price could vary, depending on which system and maker is chosen.

Table 27 – Specific fuel oil consumption

	SFOC (specific fuel oil consumption)			
	HFO	LS MGO	LNG	
2-stroke	0,182	0,171	0,155	kg/kWhr
2-stroke (de-rated)	0,171	0,161	0,145	kg/kWhr
4-stroke	0,209	0,196	0,178	kg/kWhr
4-stroke (de-rated)	0,196	0,185	0,167	kg/kWhr

Due to the significantly higher cost of MGO compared to HFO, we have calculated the increase in running cost, with MGO, compared to running the main engine on HFO in table 35, Addition to OPEX, MGO has a higher Calorific value, which reduces the SFOC as per table 27, Specific fuel oil consumption.

Additional requirements and restrictions

- Latest emission control regulations – the International Maritime Organization (IMO)

The IMO Annex VI of MARPOL 73/78, Regulations for the Prevention of Air Pollution from Ships has been in force since May 2005. Thus, the SO_x limit applies to all vessels in the category of ships with an engine power output of more than 130 kW. The general international limit on sulphur is reduced from 5% to 4.5% through the ISO 8217 fuel standard. IMO has specified that, in future, further limitations will be imposed on SO_x as well as on other components in the exhaust gas. Figure 20, Sulphur reduction 'road map' illustrates the IMO SO_x limits or both ECAs (Emission Controlled Areas) and for international waters. CARB (California Air Resources Board) has introduced limits on the use of sulphur for MGO and MDO, respectively.

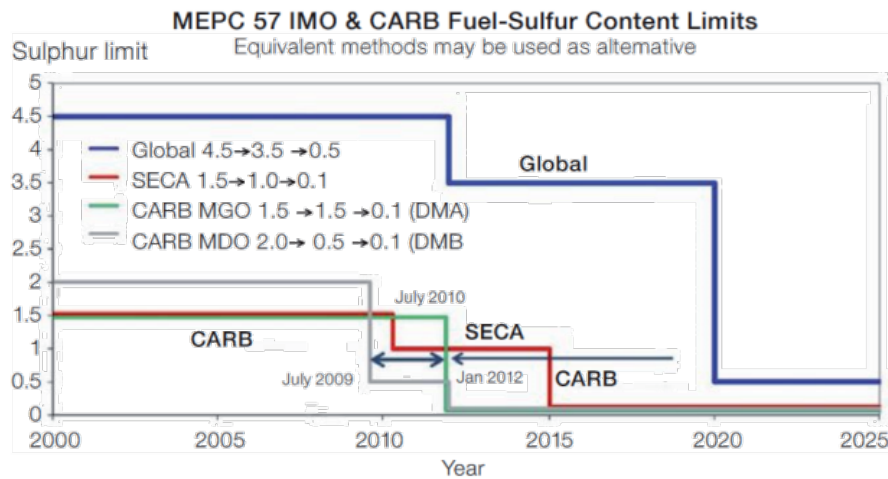

Figure 20: Sulphur reduction 'road map'

- No special requirements or regulations govern the use of distillate fuels except that the fuels are to comply with ISO 8217 standard. There are concerns regarding the safety of the use of distillate fuels (LS MGO) on oil fired boilers
- There exists a concern during a fuel changeover from HFO to distillate fuel (LS MGO) because the pipes and other parts of the fuel oil pumping system are heated when using HFO. MGO flowing through the same hot piping may vaporize creating vapour locks and causing irregular fuel flow to injectors resulting in engine stoppage. Therefore, MGO is not to be used through heated pipes to engines.
- Distillate fuels (LS MGO) is rarely found in isolated ports and is often only available by truck, which at times is a problem due to ISPS control at high profile ports.
- Engine maker's recommendation for an MGO chiller or cooling plant.
- No restrictions by Classification Society.
- No polar restrictions.

7 Exhaust gas scrubber

An EPA report from November 2011 (EPA-800-R_11_006)^(xi) reports results of preliminary studies of exhaust gas scrubber installations on 3 vessels. In November 2006, the Puget sound Clean Air Agency received funding from the EPA to evaluate whether a seawater scrubbing system could be successfully designed, retrofitted and operated within the tight confines of an existing cruise vessel. In April 2007, Holland America Line installed a seawater scrubber in the stack of one of the five 9 MW diesel generators on the cruise ship *MS Zaandam*.

We have investigated one recent exhaust gas scrubber system installed in the DFDS ro-ro vessel, *Facaria Seaways*,^(xii) as a retrofit option. We received an equipment quote from the scrubber maker, Alfa Laval/Aalborg

Industries for the base case vessel, Aframax tanker with a total motor effect of 15.840 kW. The quote for the equipment alone is EUR 2.510.000, \approx USD 3.162.600, (EUR – USD exchange rate \approx 1,26),^(xiii) excluding installation and off-hire at a shipyard. We estimated a retrofit time of 30 days for each type of vessel. After researching the average costs of the equipment, we are able to confirm that an average USD/kW price can be used to scale the price of the equipment linearly according to the power requirement for the specific vessel. The table 30, Cost per kW, for the scrubber is USD 330/kW – excl. off-hire and drydocking, which would be a typical newbuilding cost and USD 368/kW – incl. off-hire and drydocking, which would be a retrofit case.



Figure 21: *External exhaust gas scrubber*

NaOH can be supplied as a 50% solution by tanker trucks at most major ports around the world, as it is used in many industries to produce paper, soap, detergents, etc. The vessel can be supplied with large 5 m³ IBC containers with heat insulation. NaOH flakes or pellets can also be supplied, where the crew will manually have to blend the dry product with water on board. This option is not recommended to avoid spillage and human contact.



Figure 22(a): *Alfa Laval scrubber installation on DFDS ro-ro*

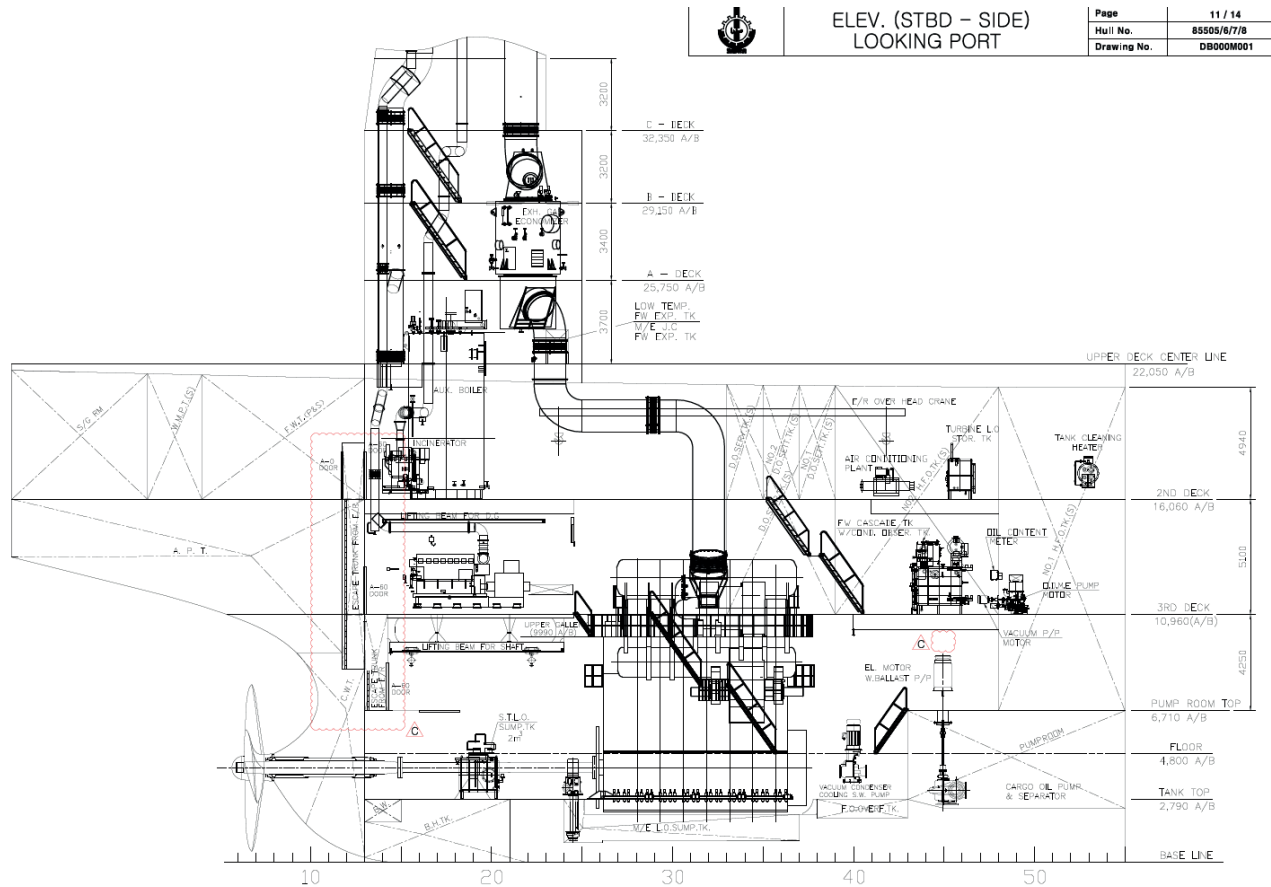

Figure 22(b): Installation layout for scrubber

Freshwater mode (FW)

While operating in FW mode, the scrubber recycles freshwater in which sodium hydroxide (NaOH) is continuously added in order to balance pH at a slightly alkaline value.

A 167 kW^(xiv) pump has been estimated on the base case, Aframax, to supply water to the scrubber. At full engine load (90% MCR, 16,000 kW), this corresponds to max 1% of the engine power. The scrubber is causing an additional back pressure of up to 30 mbar, which will also cause some additional energy consumption on the main engine. The additional energy consumption associated with the scrubber back pressure is within the uncertainties of the engine performance measurements – this is difficult to measure but estimated to 0,4 % by MAN Diesel & Turbo,^(xiv) table 28, Fuel consumption penalty for scrubber. In FW mode, energy for producing NaOH must also be taken into account. NaOH can be produced by several methods; most common is Diaphragm Cell Electrolysis, which requires 5000 kWh/ton. This corresponds to a 2% emissions penalty of energy in the HFO, table 28, Fuel consumption penalty for scrubber. The consumption of NaOH at 90% MCR of the main engine on the base case, AFRAMAX, is estimated to 265 L/hr @ an average cost of USD 9/L. This cost including the Additional Energy Consumption can be seen in table 35, Addition to OPEX. The consumption will most probably be reduced from 90% MCR, due to vessel operating at reduced RPM (15% to 40% MCR).

Seawater mode (SW)

While operating in SW mode, the scrubber uses the natural alkalinity of seawater to absorb and bind the SO_x from the exhaust gas, thus no NaOH is needed in the scrubbing process. There is an increased SW requirement through the scrubber in SW mode requiring 206kW pumps.^(xiv) This increases the power requirement to 1,2% of the engine power.

Table 28 – Fuel consumption penalty for scrubber^(xiv)

	SW Scrubbing	FW Scrubbing
Pumps	1,2%	1,0%
Engine back pressure	0,4%	0,4%
NaOH production emissions penalty	0	2%
Total	1,6%	3,4%

Additional requirements and restrictions

- An exhaust gas scrubber requires significant space on board, depending on engine output. Retrofitting challenges are to be expected on smaller vessels and vessels with restricted space in the funnel casing, e.g. tugs, fishing vessels, cruise liners and container feeder vessels.
- Special precautions should be taken when sailing to polar regions where temperatures could drop below freezing point. Heating elements are to be installed into the freshwater tanks and heat tracing cabling installed around all freshwater piping to avoid pipe bursts under extreme sub-zero conditions. Figure 22(b) installation is not recommended in polar operation areas, due to exposure to the elements. The NaOH is required to be kept above 18°C, to avoid crystallization. NaOH is not to be stored in aluminium containers to avoid a violent reaction. It is recommended that crew is made aware of the dangers of NaOH before any operation.
- MEPC 184(59) – 2009 Guidelines for Exhaust Gas Cleaning Systems^(xv) specifies the requirements for the test, certification and in-service verification of SO_x scrubbing systems. The Guidelines apply to any SO_x scrubber fitted to fuel oil combustion machinery (excluding incinerators) as an alternative method of compliance with annex VI, regulation 14.

There are two schemes available:

Scheme A under which the SO_x scrubber is subject to initial certification of SO_x reduction performance followed by continuous monitoring of operating parameters and a daily spot check of emissions performance; or Scheme B in which there is no requirement for initial certification, but continuous emissions monitoring using an approved system and a daily spot check of operating parameters are required.

- Currently the EC only accepts continuous emissions monitoring and the US Coastguard also appears to be pre-disposed to continuous emissions monitoring. Each ship fitted with a scrubbing system will require a SO_x Emissions Compliance Plan (SECP). The plan, prepared by the ship operator, must demonstrate how the ship in its entirety will comply with Regulation 14 and must be approved by the administration. It is required to cover all fuel oil combustion units on the ship, whether fitted with scrubbers or not.

8 Diesel Particle Filter (DPF)

A well-known Japanese shipping line has started preliminary tests of a DPF on a 2-stroke engine in November 2011,^(xvi) and the DPF system has already operated smoothly for over 500 hours. With research support from the Japanese Classification Society, they have jointly developed a DPF system for marine diesel engines, which run on C heavy oil. The use of particle filters in inland waterway vessels and highway trucks has been very successful.

A paper by Eelco den Boer, 'Emissions from the Legacy Fleet',^(xvii) estimates the installation cost of DPF on inland waterway vessels. The estimated CAPEX cost was reported EUR 50/kW ≈ USD 63/kW, (EUR–USD exchange rate ≈ 1,26) and the CAPEX including installation costs for a typical retrofit case would be EUR 110/kW ≈ USD 139/kW (EUR–USD exchange rate ≈ 1,26).

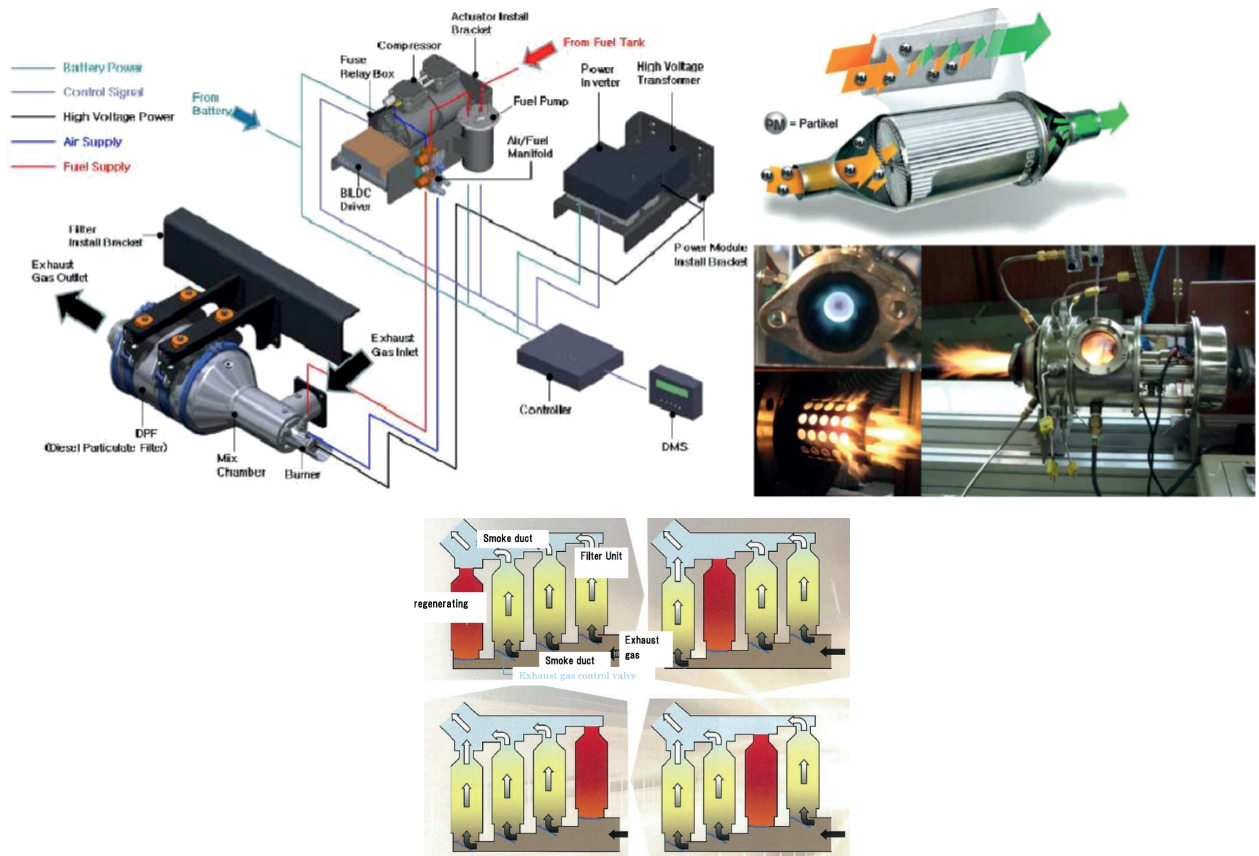

Figure 23: DPF (diesel particle filter)

This system incorporates a filter that relies on silicon carbide ceramic fibres. The filter collects particulate matter (PM) when exhaust gas goes through it. It is also a self-cleaning system that automatically combusts and eliminates PM build-up in the filter. This allows for continual operation without clogging of the filter, and requires no maintenance by seafarers. The test is scheduled for about one year (operating time: about 4,000 hours) to verify the system's PM collection performance. After that, its durability will be assessed. We estimate an additional energy penalty, due to exhaust back pressure, to be approximately 0,4% of shaft power. (xviii)

Additional requirements and restrictions

- The down side of the DPF solution is that it requires a lot of space, approximately two or three times engine volume. This is not a problem with inland waterway vessels, with small engine capacity, but is a challenge on the large commercial vessels with 2-stroke engines or cruise vessels. Installation is recommended in the design phase of the newbuilding vessels, as the size of the installation can be taken into consideration when designing the engine room, exhaust trunking and funnel casing.
- No Classification Society restrictions.
- No polar restrictions.

Table 29 – Classification of vessels

80,000 – 120,000 DWT

Length 245 m
 Beam 34 m
 Draft 20 m
 Cargo 120,000 m³



120,000 – 180,000 DWT

Length 350 m
 Beam 56 m
 Draft 15.5 m
 Cargo 156,000 m³
 Power 85,000 kW



150,000 – 180,000 DWT

Length 280 m
 Beam 43 m
 Draft 18 m
 Cargo 175,000 m³
 Power 15,000 kW

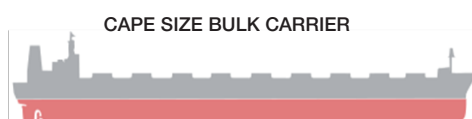

75,000 – 80,000 DWT

Length 345 m
 Beam 53.8 m
 Draft 12 m
 Cargo 162,000 m³
 Power 22,000 kW

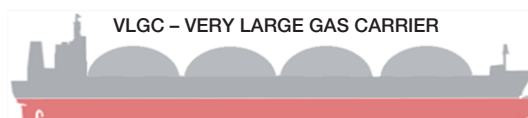

120,000 – 150,000 DWT

Length 345 m
 Beam 45 m
 Draft 10 m
 Power 75,000 kW



3,000 – 8,000 DWT

Length 90 m
 Beam 21 m
 Draft 7,5 m
 Power 16,000 kW



200 – 500 DWT

Length 36 m
 Beam 11 m
 Draft 3 – 4 m
 Power 6,100 kW



Table 30 – Cost per kW excl. off-hire cost

Abatement	Aframax	Container	Bulk carrier	Gas	Passenger	OSV/AHTS	Tug
EEDI (de-rating)	USD 100	USD 100	USD 100	USD 100	USD 100	USD 100	USD 100
Slow steaming: with de-rating	USD 100	USD 100	USD 100	USD 100	USD 100	USD 100	USD 100
WiFE	USD 26	USD 26	USD 26	USD 26	USD 26	USD 26	USD 26
LNG	USD 455	USD 518	USD 518	USD 518	USD 518	USD 518	USD 518
DPF	USD 63	USD 63	USD 63	USD 63	USD 63	USD 63	USD 63
HFO-distillate	USD 13	USD 13	USD 13	USD 13	USD 13	USD 13	USD 13
Scrubber	USD 330	USD 330	USD 330	USD 330	USD 330	USD 330	USD 330

From the table 34, CAPEX, we can see that the retrofitting of the abatement measures are more costly compared to newbuilding, due to the fact that the fixed investment cost of the equipment is approximately 80% to 90% of the capital investment. Shipyard rates around the world are relatively constant for the retrofitting of the specialized equipment. Once the abatement measure become mainstream, the equipment will become more cost effective and shipyards will also reduce the retrofitting costs, due to familiarization of the installation process. This proves that there is a relatively linear relation between shaft power and the capital investment. The shaft power of the vessel is taken as 100%MCR, table 31, Shaft power (kW)@100%MCR, table 32, Shaft power (kW) @ 90%MCR, to dimension the equipment to maximum engine output.

Table 31 – Shaft power (kW)@100%MCR

Vessel type	Shaft power (kW)
Aframax	16,000
Container	85,000
Bulk carrier	15,000
Gas	22,000
Passenger	75,000
OSV/AHTS	16,000
Tug	6,100

Table 32 – Shaft power (kW) @ 90%MCR

Vessel type	Shaft power (kW)
Aframax	14,400
Container	76,500
Bulk carrier	13,500
Gas	19,800
Passenger	67,500
OSV/AHTS	14,400
Tug	5,490

From table 35, Addition to OPEX (US\$/day), the additional operational costs for each abatement measure is calculated. This illustrates if the operational cost is a financial benefit and an approximate pay back time can be calculated for each vessel type and equipment type. The shaft power of the vessel is taken as 90% MCR, table 31, Shaft power (kW)@100%MCR, table 32, Shaft power (kW) @ 90%MCR, due to the fact that the vessel's budgetary figures are calculated on 90% MCR, where the engines are most efficient.

To retrofit the abatement measures, an off-hire rate per day, table 33, Off-hire rates, is to be estimated and multiplied by the estimated number of days the specific abatement measure takes to be installed and completed.

Table 33 – Off-hire rates

Vessel type	EEDI (de-rating)	De-rating	WiFE	LNG	HFO-distillate	DPF	Scrubber	Off-hire rates
Aframax	30	30	20	40	10	20	30	USD 20,000
Container	30	30	20	40	10	20	30	USD 40,000
Bulk carrier	30	30	20	40	10	20	30	USD 18,000
Gas	30	30	20	40	10	20	30	USD 30,000
Passenger	30	30	20	40	10	20	30	USD 60,000
OSV/AHTS	30	30	20	40	10	20	30	USD 40,000
Tug	30	30	20	40	10	20	30	USD 10,000

Table 34 – CAPEX (USD)

	EEDI (de-rating)		De-rating		Emulsion		LNG		Chiller (HFO-distillate)		DPF		Scrubber	
	Retrofit	New-building	Retrofit	New-building	Retrofit	New-building	Retrofit	New-building	Retrofit	New-building	Retrofit	New-building	Retrofit	New-building
1 Aframax	2,210,000	1,610,000	2,210,000	1,610,000	810,000	410,000	8,080,000	7,280,000	410,000	210,000	1,410,000	1,010,000	5,880,000	5,280,000
2 Container	9,730,000	8,530,000	9,730,000	8,530,000	2,970,000	2,170,000	45,630,000	44,030,000	1,500,000	1,100,000	6,160,000	5,360,000	29,240,000	28,040,000
3 Bulk carrier	2,050,000	1,510,000	2,050,000	1,510,000	740,000	380,000	8,490,000	7,770,000	370,000	190,000	1,310,000	950,000	5,490,000	4,950,000
4 Gas	3,110,000	2,210,000	3,110,000	2,210,000	1,160,000	560,000	12,600,000	11,400,000	580,000	280,000	1,990,000	1,390,000	8,160,000	7,260,000
5 Passenger	9,330,000	7,530,000	9,330,000	7,530,000	3,120,000	1,920,000	41,250,000	38,850,000	1,570,000	970,000	5,930,000	4,730,000	26,540,000	24,740,000
6 OSV/AHTS	2,660,000	1,610,000	2,660,000	1,610,000	1,110,000	410,000	9,690,000	8,290,000	560,000	210,000	1,710,000	1,010,000	6,330,000	5,280,000
7 Tug	910,000	610,000	910,000	610,000	360,000	160,000	3,560,000	3,160,000	180,000	80,000	580,000	380,000	2,310,000	2,010,000

Table 35 – Addition to OPEX (USD)

Shaft power (kW)@90% MCR	EEDI (de-rating)			De-rating		Emulsion		LNG comparison		Chiller (HFO-Distillate)		DPF		Scrubber	
	2-stroke	4-stroke	4-stroke	2-stroke	4-stroke	30 vol.% H ₂ O	20 vol.% H ₂ O	MGO	HFO	MGO (- chiller)	MGO (+ chiller)	SW mode	FW mode	SW mode	FW mode
1 Aframax	-2,600	-	-	-2,600	-	900	600	-40,800	-22,000	18,700	18,900	700	59,500	700	59,500
2 Container	-13,600	-	-	-13,600	-	4,500	3,400	-216,600	-117,100	99,500	100,600	3,600	316,100	3,600	316,100
3 Bulk carrier	-2,400	-	-	-2,400	-	800	600	-38,200	-20,700	17,600	17,700	600	55,800	600	55,800
4 Gas	-3,500	-4,000	-4,000	-3,500	-4,000	1,200	900	-56,100	-30,300	25,800	26,000	900	81,800	900	81,800
5 Passenger	-	-13,800	-	-	-13,800	4,600	3,400	-219,500	-118,600	100,900	101,800	3,700	279,900	3,700	279,900
6 OSV/AHTS	-	-2,900	-	-	-2,900	1,000	700	-46,800	-25,300	21,500	21,700	800	59,700	800	59,700
7 Tug	-	-1,100	-	-	-1,100	400	300	-17,900	-9,600	8,200	8,300	300	22,800	300	22,800

The first set of columns, table 36, Index summary of the short-list BC abatement option for 2-stroke engines, under Relevance, are divided into Retrofit and Newbuilding, which illustrates if the specific abatement measure is possible on the different type of vessel. Following relevance is the engine types, e.g. 2-stroke or 4-stroke. Approximately 90% of the world commercial fleet uses 2-stroke engines for propulsion, and due to propulsion power requirement for 90% to 98% of all power consumption on board, all other consumers are negligible where 4-stroke engines are the main source of power for propulsion.

The second set of columns, table 36, Index summary of the short-list BC abatement option for 2-stroke engines under Cost index, are divided into Retrofit and Newbuilding. This is due to the cost implications involved when retrofitting the abatement options, e.g. drydocking, off-hire, Classification Society, design, machinery modification, additional steel/piping/cabling, etc. When designing and installing the abatement measures from the Newbuilding stage, a considerable cost saving is found and recommended. The cost index varies considerably between vessel classes due to the large variances in shaft power and off-hire rates. E.g. due to the minimum available knowledge of the daily charter rate for a cruise liner, we estimated a rate of USD 60.000/day.

The third set of columns, table 36, Index summary of the short-list BC abatement option for 2-stroke engines under Reduction Index, summarizes all emissions which are being discussed during this report, e.g. NO_x, SO_x, Black Carbon, CO₂. The reduction of emissions is directly related to the fuel consumption of each vessel type, which in turn is related to the shaft power. There could be a minor improvement in reducing emissions from Newbuilding stage compared to Retrofit, but the difference is very small and thus negligible.

- (1) 90% of the commercial bulk fleet use 2-stroke engines, so the 4-stroke engines are not relevant in our estimates except for gas vessels and ocean liners.
- (2) De-rating of 4-stroke medium speed engines usually requires the engines to be replaced. Only during the newbuilding design phase will this be viable.
- (3) Diesel particle filters are being tested on inland waterway vessels but the technology needs to mature to gain more experiences and data.
- (4) De-rating & slow steaming have been taken as the most cost-effective way to reduce the EED Index.
- (5) 2-stroke engines are not possible on ocean passenger liners, supply vessels and tugs.
- (6) Retrofit of de-rated propulsion plants for 4-stroke engines is not an option due to the complete propulsion plant needs replacement and pay back time is not realistic. De-rated engines are an option in the design phase of a newbuilding; slow steaming is an option with 4-stroke propulsion, as most ocean liners, supply vessels and tugs are diesel-electric driven. This gives the vessel flexibility to reduce number of generators.
- (7) LNG retrofit for tugs is not possible due to the space requirement. If the vessel is designed to accommodate the LNG tanks, then the system can be incorporated.

If the abatement option Cost or Reduction Index per comparative vessel exceeds the Aframax tanker, the specific Index will exceed Index 100 and vice versa if the Cost or Reduction Index is less.

Table 36 – Index summary of the short-list BC abatement option for 2-stroke engines

	Aframax tanker				Cost index	
	Relevance				Retrofit	Newbuilding
	Retrofit		Newbuilding			
	2-stroke	4-stroke	2-stroke	4-stroke		
EEDI	✓ ⁽⁴⁾	– ⁽¹⁾	✓ ⁽⁴⁾	– ⁽¹⁾	100 ⁽⁴⁾	71 ⁽⁴⁾
Slow steaming: with de-rating	✓	– ⁽¹⁾	✓	– ⁽¹⁾	100	71
Water-in-fuel emulsion	✓	– ⁽¹⁾	✓	– ⁽¹⁾	100	48
LNG	✓	– ⁽¹⁾	✓	– ⁽¹⁾	100	89
HFO – distillate	✓	– ⁽¹⁾	✓	– ⁽¹⁾	100	71
Diesel particle filters	✓ ⁽³⁾	– ⁽¹⁾	✓ ⁽³⁾	– ⁽¹⁾	100 ⁽³⁾	69 ⁽³⁾
Scrubbers – high sulphur	✓	– ⁽¹⁾	✓	– ⁽¹⁾	100	90

	13,000 – 15,000 TEU container vessel				Cost index	
	Relevance				Retrofit	Newbuilding
	Retrofit		Newbuilding			
	2-stroke	4-stroke	2-stroke	4-stroke		
EEDI	–	– ⁽¹⁾	✓ ⁽⁴⁾	– ⁽¹⁾	433 ⁽⁴⁾	530 ⁽⁴⁾
Slow steaming: with de-rating	✓	– ⁽¹⁾	✓	– ⁽¹⁾	433	530
Water-in-fuel emulsion	✓	– ⁽¹⁾	✓	– ⁽¹⁾	358	530
LNG	✓	– ⁽¹⁾	✓	– ⁽¹⁾	561	605
HFO – distillate	✓	– ⁽¹⁾	✓	– ⁽¹⁾	440	536
Diesel particle filters	✓ ⁽³⁾	– ⁽¹⁾	✓ ⁽³⁾	– ⁽¹⁾	429 ⁽³⁾	530 ⁽³⁾
Scrubbers – high sulphur	✓	– ⁽¹⁾	✓	– ⁽¹⁾	494	531

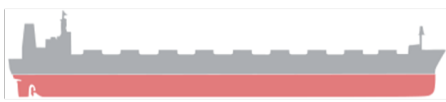
	Cape size bulk carrier				Cost index	
	Relevance				Retrofit	Newbuilding
	Retrofit		Newbuilding			
	2-stroke	4-stroke	2-stroke	4-stroke		
EEDI	✓ ⁽⁴⁾	– ⁽¹⁾	✓ ⁽⁴⁾	– ⁽¹⁾	93 ⁽⁴⁾	94 ⁽⁴⁾
Slow steaming: with de-rating	✓	– ⁽¹⁾	✓	– ⁽¹⁾	93	94
Water-in-fuel emulsion	✓	– ⁽¹⁾	✓	– ⁽¹⁾	92	95
LNG	✓	– ⁽¹⁾	✓	– ⁽¹⁾	105	107
HFO – distillate	✓	– ⁽¹⁾	✓	– ⁽¹⁾	93	94
Diesel particle filters	✓ ⁽³⁾	– ⁽¹⁾	✓ ⁽³⁾	– ⁽¹⁾	92 ⁽³⁾	93 ⁽³⁾
Scrubbers – high sulphur	✓	– ⁽¹⁾	✓	– ⁽¹⁾	93	94





	VLGC (Very Large Gas Carrier)				Cost index	
	Relevance				Retrofit	Newbuilding
	Retrofit		Newbuilding			
	2-stroke	4-stroke	2-stroke	4-stroke		
EEDI	✓ ⁽⁴⁾	✓ ⁽⁴⁾	✓ ⁽⁴⁾	✓ ⁽⁴⁾	141 ⁽⁴⁾	137 ⁽⁴⁾
Slow Steaming: with De-Rating	✓	✓	✓	✓	141	137
Water-in-Fuel Emulsion	✓	✓	✓	✓	144	138
LNG	✓	✓	✓	✓	156	157
HFO-Distillate	✓	✓	✓	✓	141	138
Diesel Particle filters	✓ ⁽³⁾	✓ ⁽³⁾	✓ ⁽³⁾	✓ ⁽³⁾	141 ⁽³⁾	137 ⁽³⁾
Scrubbers-High Sulphur	✓	✓	✓	✓	139	137

Table 37 – Index summary of the short-list BC abatement option for 4-stroke engines

	Ocean liner				Cost index	
	Relevance				Retrofit	Newbuilding
	Retrofit		Newbuilding			
	2-stroke	4-stroke	2-stroke	4-stroke	Retrofit	Newbuilding
EEDI	– ⁽⁵⁾	✓ ⁽⁴⁾	– ⁽⁵⁾	✓ ⁽⁴⁾	419 ⁽⁴⁾	341 ⁽⁴⁾
Slow steaming: with de-rating	– ⁽⁵⁾	✓ ⁽²⁾	– ⁽⁵⁾	✓	419 ⁽²⁾	341
Water-in-fuel emulsion	– ⁽⁵⁾	✓	– ⁽⁵⁾	✓	381	468
LNG	– ⁽⁵⁾	✓	– ⁽⁵⁾	✓	508	534
HFO – distillate	– ⁽⁵⁾	✓	– ⁽⁵⁾	✓	423	472
Diesel particle filters	– ⁽⁵⁾	✓ ⁽³⁾	– ⁽⁵⁾	✓ ⁽³⁾	416 ⁽³⁾	467 ⁽³⁾
Scrubbers – high sulphur	– ⁽⁵⁾	✓	– ⁽⁵⁾	✓	450	469

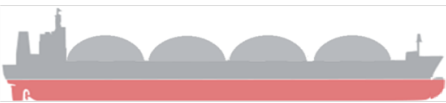
	OSV/AHTS				Cost index	
	Relevance				Retrofit	Newbuilding
	Retrofit		Newbuilding			
	2-stroke	4-stroke	2-stroke	4-stroke	Retrofit	Newbuilding
EEDI	– ⁽⁵⁾	✓ ⁽⁴⁾	– ⁽⁵⁾	✓ ⁽⁴⁾	122 ⁽⁴⁾	100 ⁽⁴⁾
Slow steaming: with de-rating	– ⁽⁵⁾	✓ ⁽²⁾	– ⁽⁵⁾	✓	122 ⁽²⁾	100
Water-in-fuel emulsion	– ⁽⁵⁾	✓	– ⁽⁵⁾	✓	139	100
LNG	– ⁽⁵⁾	✓	– ⁽⁵⁾	✓	121	114
HFO – distillate	– ⁽⁵⁾	✓	– ⁽⁵⁾	✓	121	100
Diesel particle filters	– ⁽⁵⁾	✓ ⁽³⁾	– ⁽⁵⁾	✓ ⁽³⁾	123 ⁽³⁾	100 ⁽³⁾
Scrubbers – high sulphur	– ⁽⁵⁾	✓	– ⁽⁵⁾	✓	108	100

	Tug				Cost index	
	Relevance				Retrofit	Newbuilding
	Retrofit		Newbuilding			
	2-stroke	4-stroke	2-stroke	4-stroke	Retrofit	Newbuilding
EEDI	– ⁽⁵⁾	✓	– ⁽⁵⁾	✓	41	38
Slow steaming: with de-rating	– ⁽⁵⁾	✓ ⁽²⁾	– ⁽⁵⁾	✓	41 ⁽²⁾	38
Water-in-fuel emulsion	– ⁽⁵⁾	✓	– ⁽⁵⁾	✓	44	38
LNG	– ⁽⁵⁾	✓ ⁽⁷⁾	– ⁽⁵⁾	✓	44 ⁽⁷⁾	43
HFO – distillate	– ⁽⁵⁾	✓	– ⁽⁵⁾	✓	41	38
Diesel particle filters	– ⁽⁵⁾	✓ ⁽³⁾	– ⁽⁵⁾	✓ ⁽³⁾	42 ⁽³⁾	38 ⁽³⁾
Scrubbers – high sulphur	– ⁽⁵⁾	✓	– ⁽⁵⁾	✓	39	38

We have based our comparative index, table 36, Index summary of the short-list BC abatement option for 2-stroke engines, on an Aframax tanker. We have given all the abatement options Index 100, for this vessel. All the following vessels that have similar length/breadth dimensions are given a calculated Index based on our Aframax tanker.

We have calculated an average Cost and Reduction Index, table 36, Index summary of the short-list BC abatement option for 2-stroke engines, for each vessel, based on shaft power (kW average). If the comparative vessel has an increased power requirement, then the Cost Index is directly proportional to the power, tables 31, Shaft power (kW) @100%MCR, and table 32, Shaft power (kW) @ 90%MCR.

References for appendix E

- ⁱ Kristensen HO, et al. (2012) Energy Efficiency Design Index Regulations from IMO (MEPC), Latest update – January 2012
- ⁱⁱ MAN Diesel, (2012) Improved Efficiency and Reduced CO₂
- ⁱⁱⁱ Lloyd's Register, (2012) MARPOL Annex VI – Approved Method (<http://www.lr.org/compliance/codes/203236-MARPOLAnnexVIApprovedMethod.aspx>)
- ^{iv} MEPC.1/Circ.678 (2009), DEFINITIONS FOR THE COST EFFECTIVENESS FORMULA IN REGULATION 13.7.5 OF THE REVISED MARPOL ANNEX VI
- ^v Andreasen, A. (MAN Diesel) & Nyggard K.B. (Danisco) (2011), Danish Ministry of the Environment (Water-in-fuel emulsion as marine engine fuel for reduced NO_x and particulate emissions – Environmental Project No. 1380 2011)
- ^{vi} MAN Diesel (2006), Faster Freight Cleaner Air
- ^{vii} Wartsila Technical Journal (2012), LNG Conversions for Marine Installations
- ^{viii} Germanischer Lloyd & MAN Diesel (2012), Cost and benefits of LNG as ship fuel for container vessels
- ^{ix} DSME, DSME Green Ship Technology is Certified by Classifications. (http://www.dsme.co.kr/epub/ds/td/dstd030Q.do?dt_type=etod&dt_seq_no=2604¤tPageNo=1)
- ^x MAN Diesel, Operation on Low-Sulphur Fuels
- ^{xi} United States Environmental Protection Agency (2011), Exhaust Gas Scrubber Wastewater Effluent (Report # EPA-800-R-11-006)
- ^{xii} Hansen, J.P. Ph.D. Chem. Eng. (2012), Alfa Laval & Danish Ministry of the Environment (Exhaust Gas Scrubber Installed Onboard MV Ficaria Seaways)
- ^{xiii} Alfa Laval (2012), Budgetary Quotation for PureSO_x
- ^{xiv} Alfa Laval (2012), Technical Specification – PureSO_x comb 128-Multiple inlet-Hybrid System
- ^{xv} MEPC 184(59) – 2009 Guidelines for Exhaust Gas Cleaning Systems
- ^{xvi} Mitsui O.S.K Lines (MOL) (2010), MOL Develops Marine Use Diesel Particulate Filter
- ^{xvii} den Boer E. (2011), (CE Delft) 'Emissions from the Legacy Fleet'
- ^{xviii} Korean Register (KR) (2010), Energy & Environmental Business Center



IMO is the specialized agency of the United Nations with responsibility for ensuring that lives at sea are not put at risk and that the environment is not polluted by international shipping. The Convention establishing IMO was adopted in 1948 and IMO first met in 1959. IMO's 170 member States use IMO to develop and maintain a comprehensive regulatory framework for shipping. IMO has adopted more than 50 binding treaty instruments, covering safety, environmental concerns, legal matters, technical co-operation, maritime security and the efficiency of shipping. IMO's main Conventions are applicable to almost 100% of all merchant ships engaged in international trade.

This study was carried out and published using funds provided to IMO by Transport Canada for analytical studies and other activities pertaining to the control of air related emissions from ships.